



3-8850.090-2

Rev.H 8/06

English



CAUTION!

- Remove power to unit before wiring input and output connections.
- Follow instructions carefully to avoid personal injury.

Contents

1. Installation
2. Specifications
3. Electrical Connections
4. Menu Functions



1. Installation

ProcessPro transmitters are available in two styles: panel mount and field mount. The panel mount is supplied with the necessary hardware to install the transmitter. This manual includes complete panel mounting instructions.

Field mounting requires a separate mounting kit. The 3-8050 Universal kit enables the transmitter to be installed virtually anywhere. Detailed instructions for field installation options are included with the 3-8050 Universal kit.

1.1 Panel Installation

1. The panel mount transmitter is designed for installation using a 1/4 DIN Punch. For manual panel cutout, an adhesive template is provided as an installation guide. Recommended clearance on all sides between instruments is 1 inch.
2. Place gasket on instrument, and install in panel.
3. Slide mounting bracket over back of instrument until quick-clips snap into latches on side of instrument.
4. To remove, secure instrument temporarily with tape from front or grip from rear of instrument. **DO NOT RELEASE.** Press quick-clips outward and remove.

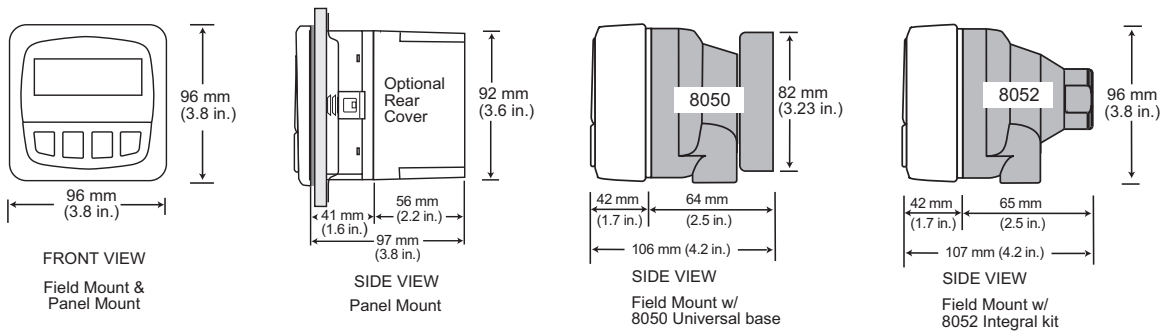

2. Specifications

General

Compatible electrodes:

Signet 3-28XX-1 Standard and Certified (NIST) Series

Conductivity/Resistivity Electrodes

Accuracy: $\pm 2\%$ of reading

Enclosure:

- Rating: NEMA 4X/IP65 front
- Case: PBT
- Panel case gasket: Neoprene
- Window: Polyurethane coated polycarbonate
- Keypad: Sealed 4-key silicone rubber
- Weight: Approx. 325g (12 oz.)

Display:

- Type: Alphanumeric 2 x 16 LCD
- Contrast: User selected, 5 levels
- Update rate: 1.8 s

Electrical

Power: 12 to 24 VDC $\pm 10\%$, regulated, 290 mA max.

Sensor input range:

- Conductivity: 0.01 $\mu\text{S}/\text{cm}$ to 400 000 $\mu\text{S}/\text{cm}$
- Resistivity: 10 $\text{K}\Omega\cdot\text{cm}$ to 100 $\text{M}\Omega\cdot\text{cm}$
- TDS: 0.023 to 200 000 PPM nominal (adjustable $\mu\text{S}/\text{PPM}$)
- Temperature: PT 1000, -25 to 120°C (-13 to 248°F)
Measurements above 10 $\text{M}\Omega$ (below 0.1 μS) must be performed in solution temperatures from 20°C to 100°C.

4 to 20 mA Outputs:

- Passive, isolated, fully adjustable and reversible 4 to 20 mA outputs are independently source selectable for conductivity or temperature.

- Max loop impedance: 50 Ω max. @ 12 V
325 Ω max. @ 18 V
600 Ω max. @ 24 V

- Update rate: 200 ms
- Accuracy: ± 0.03 mA @ 25°C, 24 V

Relay outputs (2 sets mechanical SPDT contacts):

- Maximum voltage rating: 5 A @ 30 VDC, or 5 A @ 250 VAC, resistive load
- Hi or Lo programmable with adjustable hysteresis
- Pulse programmable (maximum 400 pulses/minute)

Environmental

- Operating temperature: -10 to 70°C (14 to 158°F)
- Storage temperature: -15 to 80°C (5 to 176°F)
- Relative humidity: 0 to 95%, non-condensing
- Maximum altitude: 2000 m (6562 ft)
- Insulation category: II
- Pollution degree: 2

Standards and Approvals

- CE, UL listed
- Immunity: EN50082-2
- Emissions: EN55011 Class B
- Manufactured under ISO 9001 and ISO 14001

U.S.A. Patent # 5,708,363

3. Electrical Connections



Caution: Failure to fully open terminal jaws before removing wire may permanently damage instrument.

Wiring Procedure

1. Remove 0.5 - 0.625 in. (13-16 mm) of insulation from wire end.
2. Press the orange terminal lever downward with a small screwdriver to open terminal jaws.
3. Insert exposed (non-insulated) wire end in terminal hole until it bottoms out.
4. Release orange terminal lever to secure wire in place. Gently pull on each wire to ensure a good connection.



Wiring Removal Procedure

1. Press the orange terminal lever downward with a small screwdriver to open terminal jaws.
2. When fully open, remove wire from terminal.

Wiring Tips:

- Do not route sensor cable in conduit containing AC power wiring. Electrical noise may interfere with sensor signal.
- Routing sensor cable in grounded metal conduit will help prevent electrical noise and mechanical damage.
- Seal cable entry points to prevent moisture damage.
- Only one wire should be inserted into a terminal. Splice double wires outside the terminal.

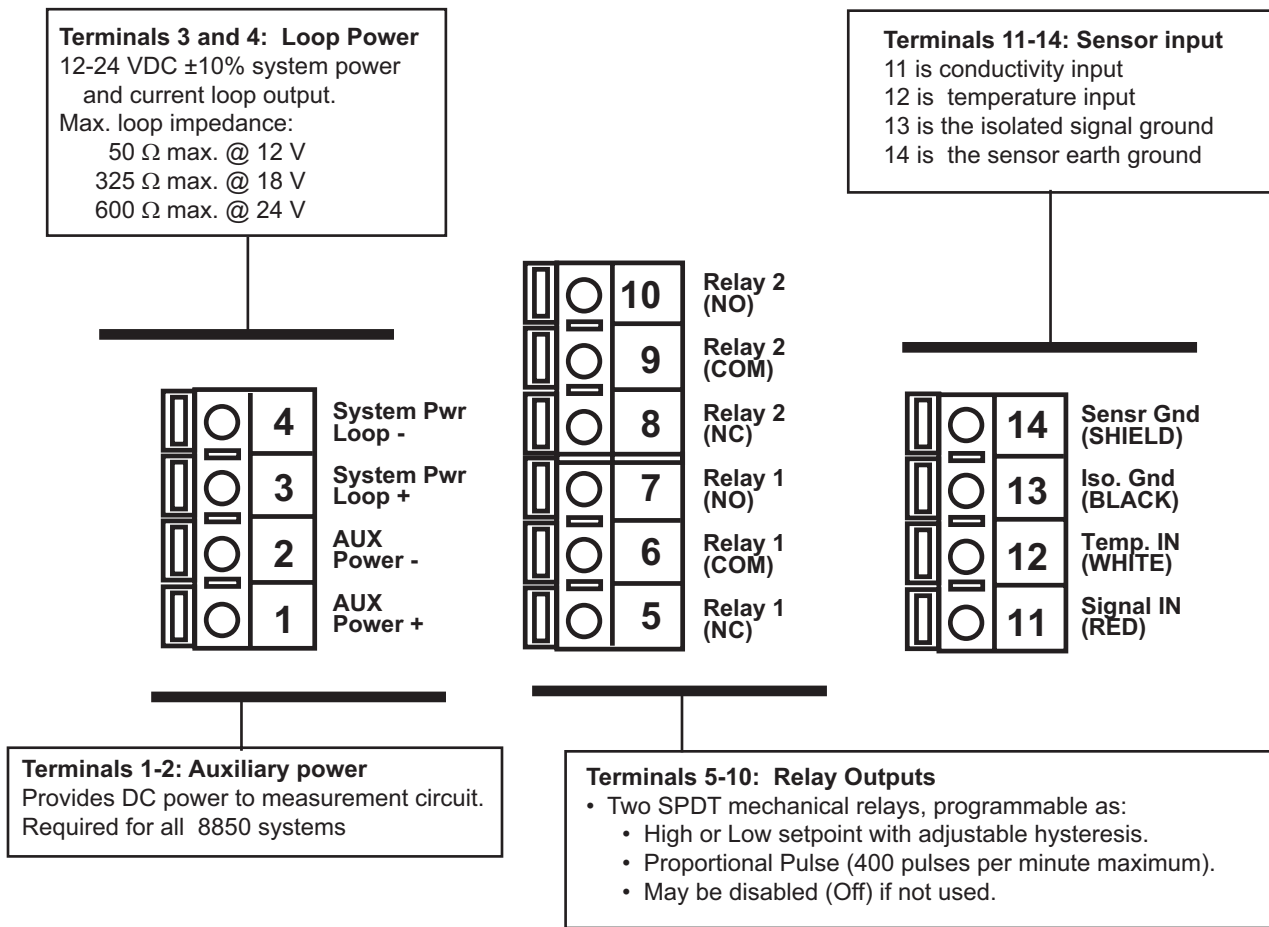

3.1 Sensor Input Connections

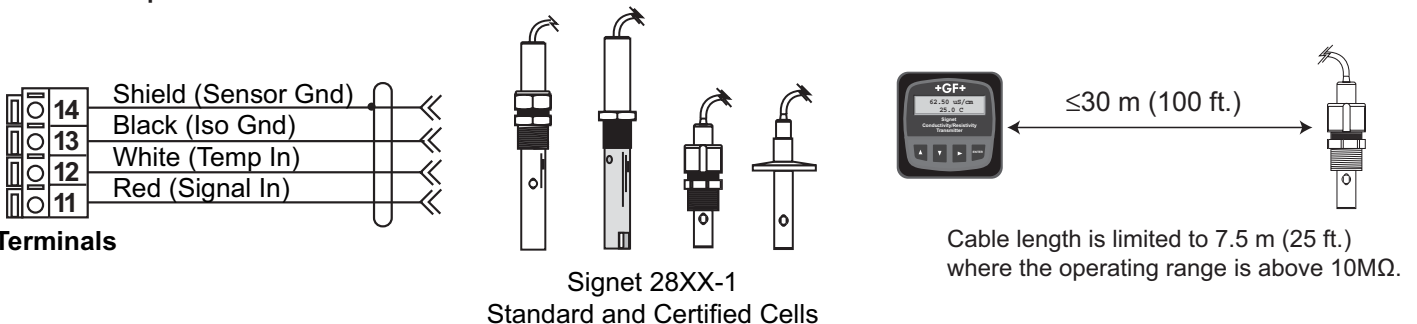

Select the sensor with the range that best straddles your application requirements.

- 2819-1, 2839-1 (0.01 cell): 0.01 to 100 μS
(10 k Ω to 100 M Ω)

Use the 2819-1 or the 2839-1 for all resistivity requirements

- 2820-1, 2840-1 (0.1 cell): 1 to 1000 μS
- 2821-1, 2841-1 (1.0 cell): 10 to 10,000 μS
- 2822-1, 2842-1 (10.0 cell): 100 to 200,000 μS
- 2823-1 (20.0 cell): 200 to 400,000 μS

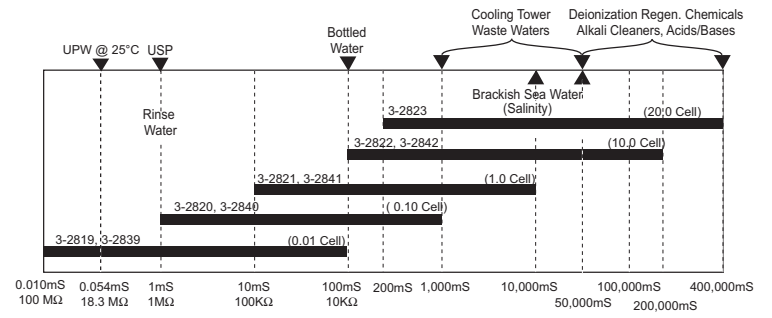

3.2 System Power/Loop Connections

Stand-alone application, no current loop used

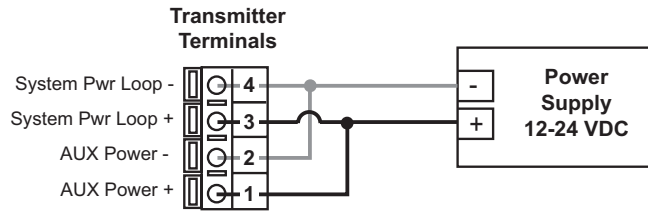

Connection to a PLC/Recorder, separate supply

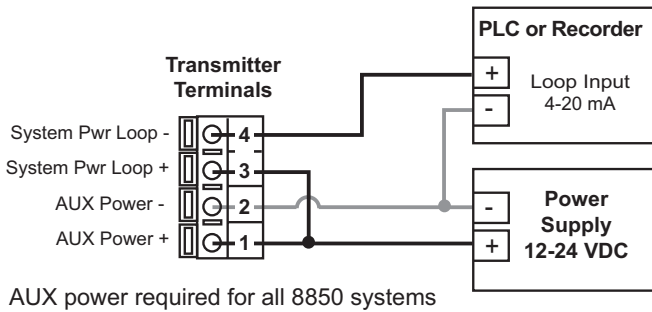

Connection to a PLC with built-in power supply

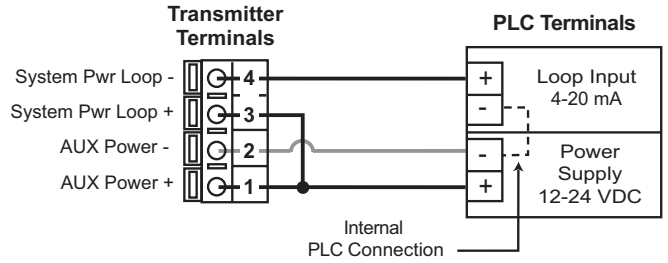

Example: Two transmitters connected to PLC/Recorder with separate power supply

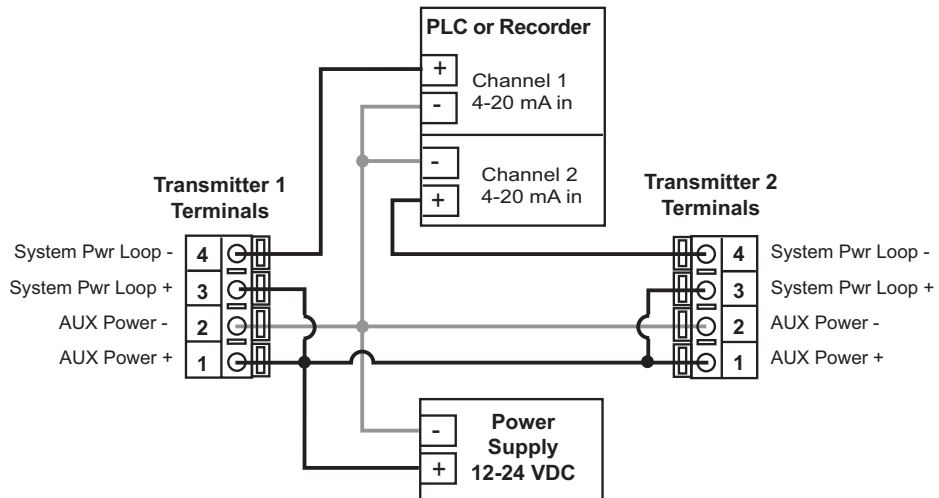

3.3 Relay Output

The relays can be used as a switch that responds when the process value moves above or below a setpoint, or to generate a pulse at a rate proportional to the process value.



- **Low:**

Relay triggers when process is less than the setpoint. The relay will relax when the process moves above the setpoint plus the hysteresis value.

- **High:**

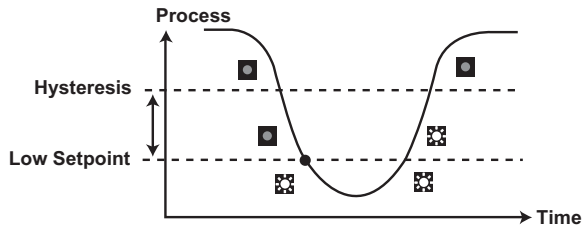
Relay triggers when process is greater than the setpoint. The relay will relax when the process moves below the setpoint plus the hysteresis value.



Relay energized 
Relay relaxed 

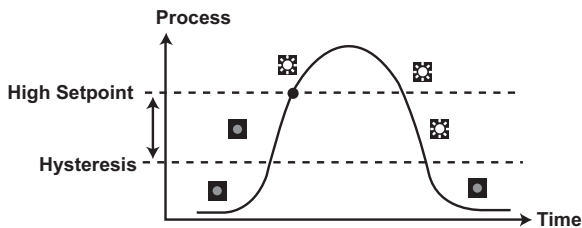

- **Proportional Pulsing**

The relay will generate a 100 mS pulse at the rate defined by settings in the CALIBRATE menu.

In the example below:

- The output will be 0 pulses/min. when value is less than 5.
- The output will be 50 pulses/min. when value is 7.5.
- The output will be 100 when value is greater than 10.

The starting point, endpoint and maximum pulse rate are selectable in the CALIBRATE menu.

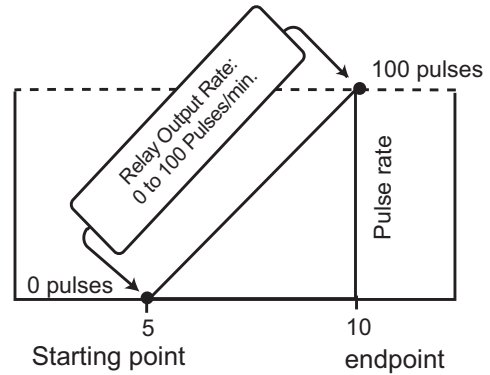

VIEW menu

- During normal operation, ProcessPro displays the VIEW menu.
- When editing the CALIBRATE or OPTIONS menus, ProcessPro will return to the VIEW menu if no activity occurs for 10 minutes.
- To select a VIEW display, press the UP or DOWN keys. The selections will scroll in a continuous loop.
- Changing the VIEW display does not interrupt system operations.
- No key code is necessary to change display selection.
- Output settings cannot be edited from the VIEW menu.



View Menu

Display	Description
1234.5 μ S +67.89 $^{\circ}$ C	Monitor the Conductivity and temperature values from the sensor. This is the permanent display.

The VIEW displays below are temporary. The permanent display will return after 10 minutes

Loop Output: 13.75 mA	Monitor the Loop Current output.
Last CAL: 04-20-07	Check the Last Calibration date.

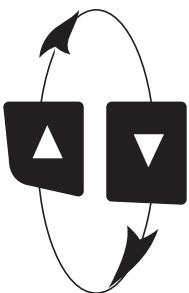

ProcessPro Editing Procedure:

Step 1. Press and hold ENTER key:

- 2 seconds to select the CALIBRATE menu.
- 5 seconds to select the OPTIONS menu.

Step 2. The Key Code is UP-UP-UP-DOWN keys in sequence.

- After entering the Key Code, the display will show the first item in the selected menu.

Step 3. Scroll menu with UP or DOWN arrow keys.

Step 4. Press RIGHT ARROW key to select menu item to be edited.

- The first display element will begin flashing.

Step 5. Press UP or DOWN keys to edit the flashing element.

- RIGHT ARROW key advances the flashing element.

Step 6. Press ENTER key to save the new setting and return to Step 3.

Notes on Step 1:

- The View Menu is normally displayed.
- The CALIBRATE and OPTIONS menus require a KEY CODE.

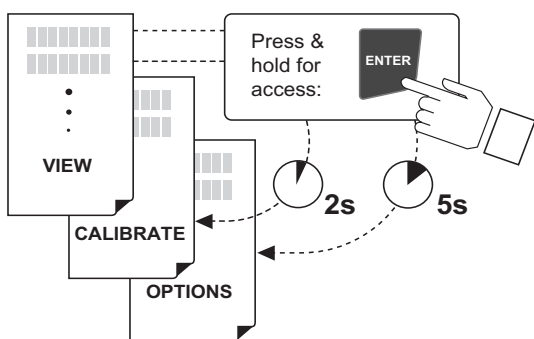

Notes on Step 2:

If no key is pressed for 5 minutes while display is showing "Enter Key Code", the display will return to the VIEW menu.

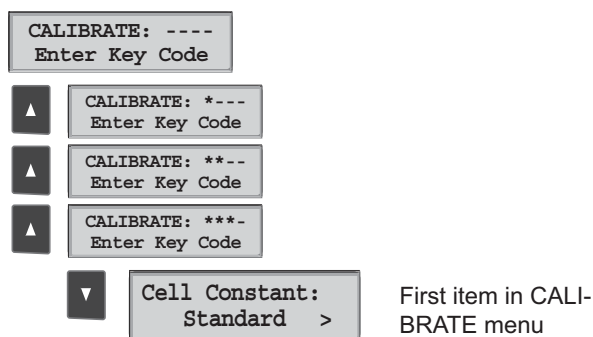

Notes on Steps 3 and 4:

- Refer to pages 6 and 7 for complete listing of menu items and their use.
- From the Step 3 display, pressing the UP and DOWN keys simultaneously will return the display to the VIEW menu.
- If no key is pressed for 10 minutes, display will also return to the VIEW menu.



Step 3: Finished Editing?
Press the UP and DOWN keys simultaneously after saving the last setting to return to normal operation.

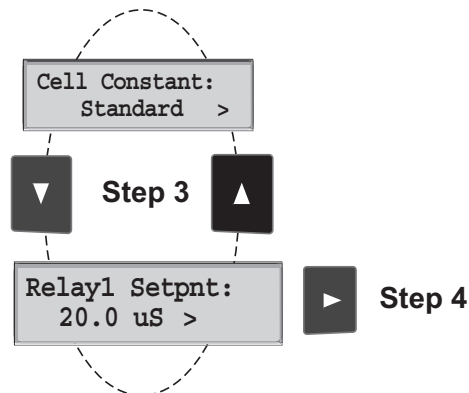

Notes on Steps 5 and 6:

- All output functions remain active during editing.
- Only the flashing element can be edited.
- RIGHT ARROW key advances the flashing element in a continuous loop.
- Edited value is effective immediately after pressing ENTER key.
- If no key is pressed for 10 minutes unit will restore the last saved value and return to step 3.
- Step 6 (pressing ENTER key) always returns you to Step 3.
- Repeat steps 3-6 until all editing is completed.

Step 5: Made an Error?

Press the UP and DOWN keys simultaneously while any element is flashing. This will recall the last saved value of the item being edited and return you to Step 3.



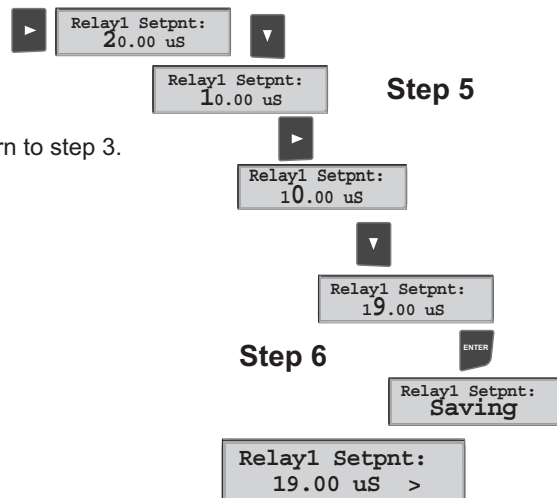

Calibrate Menu

Display (Factory settings shown)	Description
Cell Constant: Standard >	Select CUSTOM only if you are connecting a certified conductivity sensor. Select STANDARD for all other systems.
Cell: Standard 1 >	For STANDARD sensors: Select from these options: 0.01, 0.1, 1.0, 10.0 or 20.0.
Cell: Custom 1.0000 >	For CUSTOM sensors: Enter the precise cell constant from the certificate provided with your sensor, or from the information label on the sensor.
Cond Units: µS >	Select from these options: µS/cm, mS/cm, kΩ•cm, MΩ•cm, PPM
PPM Factor: 2.00 >	If the Units selection is PPM, set the ratio of Total Dissolved Solids to µS. The maximum allowable is 3 µS = 1 PPM. The TDS factor can only be set in PPM.
Set: Temperature >	Adjust the temperature of the system based on an accurate external reference.
Set: Conductivity >	For use with STANDARD sensors: Perform this single-point wet calibration for most accurate results. Not required for CUSTOM sensors except for periodic system accuracy confirmation. Enter all zeroes to restore factory calibration to TEMP and COND settings.
Loop Source: Cond >	Select the input (Conductivity or Temperature) source to be associated with the current loop output:
Loop Range: µS 0.0000 → 100.000 >	Select the minimum and maximum values for the current loop output. Be sure to modify this setting if you change the Cond. Units.
Relay1 Source: Cond >	Select the source (Conductivity or Temperature) for this relay output:
Relay1 Mode: Low >	Select the mode of operation for the relay. Options available are High, Low or proportional Pulse. The relay may be disabled (Off) if not in use.
Relay1 Setpnt: 10.0000 µS >	In Low or High Mode, the relay will be activated when the process reaches this value. Be sure to modify this setting if you change the Cond. Units.
Relay1 Hys: µS 0.5000 >	The relay will be deactivated at Setpoint ± Hysteresis, depending on High or Low Setpoint selection.
Relay1 Rng: µS 10.0000 → 40.0000 >	In Pulse mode, set the process values where the proportional pulse will start and where it will reach the maximum rate. Be sure to modify this setting if you change the Cond. Units.
Relay1 PlsRate: 120 Pulses/Min >	In Pulse mode, set the maximum rate for the proportional Pulse. The 8850 will accept any value from 0 to 400.
Last CAL: 04-20-07 >	Use this "note pad" to record important dates, such as annual recertification or scheduled maintenance.

Options Menu

Display (Factory settings shown)	Description
Contrast: 3 >	Adjust the LCD contrast for best viewing. A setting of 1 is lower contrast, 5 is higher. In general, select lower contrast if the display is in warmer ambient surroundings.
Cond Decimal: ****.* >	Set the decimal to the best resolution for your application. The display will automatically scale up to this restriction. Select *****, ****.*, ***.* **.* or *.*
Averaging: Off >	OFF provides the most instantaneous response to process changes. Select LOW (4 sec) or HIGH (8 sec) averaging if your process experiences frequent or extreme fluctuations.
Loop Adjust: 4.00 mA >	Adjust the minimum and maximum current output. The display value represents the precise current output. Adjustment limits: • 3.80 mA < 4.00 mA > 5.00 mA • 19.00 mA < 20.00 mA > 21.00 mA Use this setting to match the system output to any external device.
Loop Adjust: 20.00 mA >	
Temp Display: °C >	Select °C or °F.
Temperature Comp %: 2.00 >	Set the percent change in Conductivity caused by a 1°C change in temperature. May be from 0.00 to 10.00.
Test Loop: >	Press UP and DOWN keys to manually order any output current value from 3.8 mA to 21.00 mA to test the output loop.
Test Relay1: >	Press UP and DOWN keys to manually toggle the relay state.

Calibration Procedure

This instrument has been electronically calibrated at the factory.

- Procedure A verifies the accuracy and linearity of the instrument by simulating temperature and conductivity values with precision ($\pm 0.1\%$) fixed resistors.
- Procedure B is a wet calibration. This procedure uses the sensor input and NIST traceable test solutions. When done correctly, this procedure offers the most accurate system calibration.

A) Accuracy Verification with Precision Resistors (Electronic Calibration):

1. Simulate the Temperature

The temperature input to the 8850 is a PT-1000 thermistor, where 1000 Ohms (Ω) is equal to 0°C and a change of 3.84Ω equals a 1°C change. ($1000 \Omega = 0^\circ\text{C}$, $1003.84 \Omega = 1.0^\circ\text{C}$, $1007.68 \Omega = 2.0^\circ\text{C}$ $1096 \Omega = 25^\circ\text{C}$)

- Connect a resistor (1000Ω to 1096Ω) between "Temp IN" and "Iso. Gnd" terminals.
- Set Temp; Adjust the temperature to exact value based on the measured resistance. (see Editing Procedure, Calibrate menu).
- To verify the temperature linearity, connect a second resistor value to the terminals.
- If the instrument does not display the correct value, service is required. ($\pm 0.5^\circ\text{C}$)

2. Simulate the Conductivity

You may calculate the exact Resistance needed to simulate a specific conductivity value, or you may calculate the exact Conductivity based on a resistor value:

$$\text{Resistance} = \frac{\text{Cell constant}}{\text{conductivity (Siemens*)}} \quad \text{e.g.} \quad \frac{0.1 \text{ Cell}}{0.000020 \text{ (Siemens*)}} = 5,000 \Omega \text{ or } 5 \text{ K}\Omega$$

$$\text{Conductivity} = \frac{\text{Sensor cell}}{\text{Simulation resistance } (\Omega)} \quad \text{e.g.} \quad \frac{0.1 \text{ Cell}}{100,000 (\Omega)} = 0.000001 \text{ Siemens* or } 1 \mu\text{S/cm}$$

(*1 $\mu\text{S} = 1 \times 10^{-6}$ Siemens or 0.000001 Siemens)

- Connect the conductivity resistor between the "Signal IN" and "Iso Gnd" terminals.
- Set Cond: Adjust the conductivity value based on the resistor value. (see Editing Procedure and Calibrate menu).
- Verify the linearity of the instrument by connecting a second resistor of a different value.
- If the instrument does not display the correct value ($\pm 2\%$ of reading), service is required.

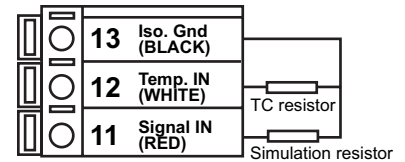

B) Wet Calibration with NIST Traceable Solutions:

When using NIST traceable standards, review the temperature information provided with the test solution. Prevent contamination of the test solution. The sensor must be at the temperature specified on the test solution label.

- Remove the sensor from the system. Rinse the sensor in a small amount of test solution.
- Place the sensor into the test solution.
- Place a reference thermometer into the same solution.
- Allow sufficient time for the temperature to stabilize.
- Set Temp: Adjust the temperature value based on the reference thermometer. (see Editing Procedure.)
- Set Cond: Adjust the conductivity value based on the test solution value. (see Editing Procedure.)
- Verify the linearity by placing the sensor into a second test solution of a different value.
- If the instrument does not display the correct value (Temperature $\pm 0.5^\circ\text{C}$, Conductivity $\pm 2\%$ of reading), service is required.

Temperature Coefficient

Conductivity measurement is highly dependent on temperature. Temperature dependence is expressed as the relative change per °C, commonly known as percent/°C change from 25°C, or slope of the solution.

Slopes can vary significantly depending on process solution type. The factory default temperature compensation factor is 2.00%/°C. Process solutions may require adjustment for maximum accuracy. To determine the optimum temperature compensation factor for a process:

1. Disable the 8850 temperature compensation % factor by entering 0.00.
2. Heat the sample solution close to the maximum process temperature. Place sensor in the sample solution allowing several minutes for stabilization. Access the VIEW menu and record the displayed temperature and conductivity values in the spaces provided:

Displayed temperature: T1 = _____ °C
Displayed conductivity: C1 = _____ μS

Do not use this procedure for solutions from 0.055 μS to 0.1 μS (10 MΩ to 18 MΩ). An internal pure water curve is used for these ranges. The factory default setting of 2.00% per °C should be used.

3. Cool the sample solution close to the minimum process temperature. Place sensor in the sample solution allowing several minutes for stabilization. Record displayed temperature and conductivity values in the spaces provided:

Displayed temperature: T2 = _____ °C
Displayed conductivity: C2 = _____ μS

(A 10% change in conductivity between steps 2 and 3 is recommended.)

4. Substitute recorded readings (steps 2 and 3) into the following formula:

$$TC \text{ Slope} = \frac{100 \times (C1 - C2)}{(C2 \times (T1 - 25)) - (C1 \times (T2 - 25))}$$

Example: A sample solution has a conductivity of 205 μS @ 48°C. After cooling the solution, the conductivity was measured at 150 μS @ 23°C. (C1 = 205, T1 = 48, C2 = 150, T2 = 23)
The TC is calculated as follows:

$$TC \text{ Slope} = \frac{100 \times (205 - 150)}{(150 \times (48 - 25)) - (205 \times (23 - 25))} = \frac{5500}{3860} = 1.42\%/^{\circ}C$$

Parts Per Million (PPM) Factor

This feature is only applicable when PPM display units are selected. The programmable PPM Factor is adjustable from 0.01 to 3.00 (factory default = 2.00).

Determine the best PPM Factor for a process solution by calculating the solution's conductivity (μS) and the percent of total dissolved solids (PPM).

$$PPM \text{ Factor} = \frac{\text{Solution conductivity } (\mu\text{S/cm})}{\text{Total dissolved solids (PPM)}}$$

$$TDS \text{ (PPM)} = \frac{\text{Solution conductivity } (\mu\text{S/cm})}{PPM \text{ Factor}}$$

- Example:
- Solution conductivity = 400 μS/cm
 - TDS = 200 PPM (mg/L)

$$PPM \text{ Factor} = \frac{400 \mu\text{S/cm}}{200 \text{ PPM}} = 2.00$$

Troubleshooting

Display Condition	Possible Causes	Suggested Solutions
"_ _ _ _"	Display is over range. This may be a normal condition if your process operates at/near the limits of the sensor range.	<ul style="list-style-type: none"> • Check sensor for correct range. • Check Decimal setting in OPTIONS menu. • Check Calibrate menu settings for incompatible SOURCE and RANGE values.
Value Must be less than 3	The PPM factor must be a value from 0.00 to 3.00	Set a PPM value less than 3.
Value must be greater than 0	Custom cell constant cannot be set to 0	Set cell constant to a value greater than 0
"Value must be 400 or less"	Pulse Rate cannot be greater than 400	set a pulse rate value less than 400
Display erratic, shows "0" or "-----" intermittently	Aux Power not connected	Wire 8850 according to diagram (Section 3.1)
"Too much Error Check Sensor"	<ul style="list-style-type: none"> • Defective or dirty/coated sensor • Wiring error • Fluid conductivity too low • Defective temp element 	<ul style="list-style-type: none"> • Clean or replace sensor • Check and correct wiring • Replace sensor

Technical notes

If a Current Loop is locked at 3.6 mA, the problem is related to the temperature circuit:

This occurs only if the 8850 detects a resistance from the temperature sensor that is less than 250Ω or greater than 2800Ω.

- Check the sensor wiring for open/short or poor connections on white (TEMP IN) and black (ISO GND)wires.
- The PT1000 temperature device in the sensor is defective.
- The transmitter is defective.

Auxiliary Power (terminals 1 and 2) must ALWAYS be connected for the 8850 to operate.

Notes

Ordering Information

Mfr. Part No	Code	Description
3-8850-2	159 000 230	Conductivity/Resistivity transmitter Field mount with relays
3-8850-2P	159 000 231	Conductivity/Resistivity transmitter Panel mount with relays

Parts and Accessories

Mfr. Part No	Code	Description
3-8050	159 000 184	Universal mounting kit
3-8050.395	159 000 186	Splashproof rear cover
3-8050.396	159 000 617	RC Filter kit (for relay use)
3-8052	159 000 188	3/4" Integral mounting kit
3-8052-1	159 000 755	3/4" NPT mount junction box
3-0000.596	159 000 641	Heavy duty wall mount bracket
3-8050.392	159 000 640	Model 200 retrofit adapter
3-5000.598	198 840 225	Surface mount bracket
3-5000.399	198 840 224	5 x 5 inch adapter plate for Signet retrofit
3-9000.392	159 000 368	Liquid-tight connector kit, 3 sets, 1/2 in. NPT
3-9000.392-1	159 000 839	Liquid-tight connector kit, 1 set, 1/2 in. NPT
3-9000.392-2	159 000 841	Liquid-tight connector kit, 1 set, PG 13.5
7300-7524	159 000 687	24 VDC Power Supply 7.5 W, 300mA
7300-1524	159 000 688	24 VDC Power Supply 15 W, 600mA
7300-3024	159 000 689	24 VDC Power Supply 30 W, 1.3 A
7300-5024	159 000 690	24 VDC Power Supply 50 W, 2.1 A
7300-1024	159 000 691	24 VDC Power Supply 100 W, 4.2 A

Conductivity/Resistivity Electrodes

Mfr. Part No.	Code	Description
3-2819-1	198 844 010	Conductivity/Resistivity (CR) Cell, 0.01, SS
3-2820-1	198 844 000	Conductivity Cell, 0.1, SS
3-2821-1	198 844 001	Conductivity Cell, 1.0, SS
3-2822-1	198 844 002	Conductivity Cell, 10, SS
3-2823-1	198 844 003	Conductivity Cell, 20, SS
3-2819-S1	159 000 085	CR Sanitary, 0.01, SS, 1 to 1 1/2 in.
3-2819-S1C	159 000 087	CR Sanitary, 0.01, SS, 1 to 1 1/2 in., Certified
3-2819-S2	159 000 086	CR Sanitary, 0.01, SS, 2 in.
3-2819-S2C	159 000 088	CR Sanitary, 0.01, SS, 2 in., Certified
3-2819-T1	159 000 081	CR Sanitary, 0.01, Titanium, 1 to 1 1/2 in.
3-2819-T1C	159 000 083	CR Sanitary, 0.01, Titanium, 1 to 1 1/2 in., Certified
3-2819-T2	159 000 082	CR Sanitary, 0.01, Titanium, 2 in.
3-2819-T2C	159 000 084	CR Sanitary, 0.01, Titanium, 2 in., Certified
3-2820-S1	159 000 089	CR Sanitary, 0.1, SS, 1 to 1 1/2 in.
3-2820-S1C	159 000 091	CR Sanitary, 0.1, SS, 1 to 1 1/2 in., Certified
3-2820-S2	159 000 090	CR Sanitary, 0.1, SS, 2 in.
3-2820-S2C	159 000 092	CR Sanitary, 0.1, SS, 2 in., Certified
3-2820-T1	159 000 624	CR Sanitary, 0.1, Titanium, 1 to 1 1/2 in.
3-2820-T2	159 000 625	CR Sanitary, 0.1, Titanium, 2 in.
3-2821-S1	159 000 093	CR Sanitary, 1.0, SS, 1 to 1 1/2 in.
3-2821-S1C	159 000 095	CR Sanitary, 1.0, SS, 1 to 1 1/2 in., Certified
3-2821-S2	159 000 094	CR Sanitary, 1.0, SS, 2 in.
3-2821-S2C	159 000 096	CR Sanitary, 1.0, SS, 2 in., Certified
3-2821-T1	159 000 626	CR Sanitary, 1.0, Titanium, 1 to 1 1/2 in.
3-2821-T2	159 000 627	CR Sanitary, 1.0, Titanium, 2 in.
3-2839-1	159 000 921	Conductivity Cell, 0.01, 15 ft cable, NPT
3-2839-1D	159 000 923	Conductivity Cell, 0.01, 15 ft cable, ISO
3-2840-1	159 000 786	Conductivity Cell, 0.1, 15 ft cable, NPT
3-2840-1D	159 000 788	Conductivity Cell, 0.1, 15 ft cable, ISO
3-2841-1	159 000 790	Conductivity Cell, 1.0, 15 ft cable, NPT
3-2841-1D	159 000 792	Conductivity Cell, 1.0, 15 ft cable, ISO
3-2842-1	159 000 794	Conductivity Cell, 10.0, 15 ft cable, NPT
3-2842-1D	159 000796	Conductivity Cell, 10.0, 15 ft cable, ISO

NOTE: Alternate wetted materials and lengths are available through special order.
Cable length extensions to 100 ft. (30 m) are available through special order.



George Fischer Signet, Inc., 3401 Aerojet Avenue, El Monte, CA 91731-2882 U.S.A. • Tel. (626) 571-2770 • Fax (626) 573-2057
For Worldwide Sales and Service, visit our website: www.gfsignet.com • Or call (in the U.S.): (800) 854-4090

