

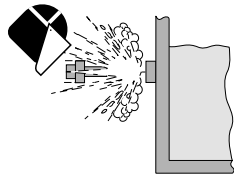

Safety Instructions



1. Prior to installation or removal:
 - Depressurize and vent system
 - Drain below sensor level
2. Confirm chemical compatibility before use.
3. Do not exceed maximum temperature/pressure specifications.
4. Wear safety goggles or faceshield during installation/service.
5. Do not alter product construction.
6. Dispose of properly; DO NOT INCINERATE!

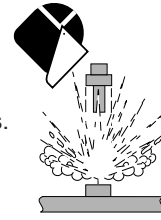

Table of Contents

1. Description
2. Specifications
3. Installation
4. (S³L) wiring
5. 4 to 20 mA wiring
6. 4 to 20 mA span adjustment
7. Ordering information

USE THE ATTACHED ADHESIVE LABEL TO PRESERVE THE SAFETY INSTRUCTIONS!

1. Description

The 2450 Pressure Sensor has a one-piece injection molded PVDF body and ceramic diaphragm for superior compatibility in corrosive liquids. These sensors are available with Digital (S³L) digital output or field-scaleable 4 to 20 mA output. Select from three (3) pressure ranges for optimal measurement resolution. Built-in temperature compensation provides outstanding accuracy over a wide operating range. Versions with 1/2 in. union process connection are best suited for in-line installations. Integral adapters (sold separately) may be used to create a compact assembly with field mount versions of the 8250 Level Transmitter and the 8450 Pressure Transmitter.

2. Specifications

General

- Compatibility: 2450 Digital (S³L) output models:
8250, 8450, 8900
2450 Current output models: PLC
- Wetted materials:
- Sensor housing: PVDF
 - Diaphragm: Ceramic
 - Seal: FPM
- Process connection:
- -1X, -5X: 3/4 in. NPT male thread, where X = L, H
 - -3X, -7X: 1/2 in. Union male thread, where X = U, L, or H
- Rear connection: 3/4 in. NPT male thread
- Cable type: 3 cond + shield, 22 AWG

- Standard cable length:
- 2450-1x, -3x, 5x, 7x: 4.6 m (15 ft)
- Sensor Accuracy: ±1% of full scale @ 25 °C
- Thermal sensitivity shift: ±0.03% of full scale per °C
- Shipping weight:
- 2450-1x, 2450-3x: 0.3 kg (0.65 lb)

Electrical

- Power Requirements:
- Digital (S³L) models: 5 to 6.5 VDC ±10%, <1.5 mA
 - 4 to 20 mA models: 12 to 24 VDC ±10% regulated
- Short circuit & reverse polarity protected

Digital (S³L) output:

- Type: Serial ASCII, TTL level 9600 bps
- Accuracy: ±1% of full scale @ 25 °C
- Repeatability: ±0.5% of full scale
- Resolution: 0.01 psi (0.001 psi for -XU)
- Update rate: <100 ms

4 to 20 mA output:

- Accuracy: ±32 µA
- Repeatability: ±0.5% of full scale
- Resolution: <5 µA
- Span: Field-scaleable (see section 6.3 for factory settings)
- Max loop impedance: 100 Ω @ 12 V
325 Ω @ 18 V
600 Ω @ 24 V
- Update rate: <100 ms

Application Limits

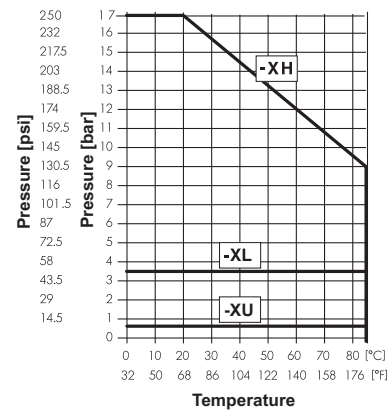

- Operating range (Max. pressure for accuracy specifications):
 - XU 0 to 0.7 bar (0 to 10 psig)
 - XL 0 to 3.4 bar (0 to 50 psig)
 - XH 0 to 17.2 bar (0 to 250 psig)
- Vacuum range:
 - XU -0.1 to 0.7 (-1.5 to 10 psi)
 - XL -0.41 to 3.4 bar (-6 to 50 psi)
 - XH -0.96 to 17.2 bar (-14.6 to 250 psi)
- Proof pressure (Max. pressure without damage):
 - XU 1.4 bar (20 psig)
 - XL 5.2 bar (75 psig)
 - XH 20.7 bar (300 psig)

Environmental

- Relative humidity: 0 to 95% (Non-condensing)
- Storage temperature: -20 °C to 100 °C (-4 °F to 212 °F)
- Operating temperature: -15 °C to 85 °C (5 °F to 185 °F)

Standards and Approvals

- CE
- Manufactured under ISO 9001 and ISO 14001
- China RoHS (Go to www.gfsignet.com for details)

Dimensions

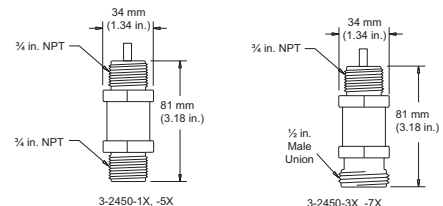

3. Installation

- Signet 2450 Pressure Sensors are gauge pressure sensors. Gauge pressure sensors measure the difference in pressure between the process on one side of a diaphragm and the atmospheric pressure on the opposite side of the diaphragm. A tiny capillary tube inside the sensor body is used to ensure that the back of the diaphragm remains at atmospheric pressure. If moisture is allowed to propagate down this tube to the rear of the diaphragm, the sensor may be damaged.

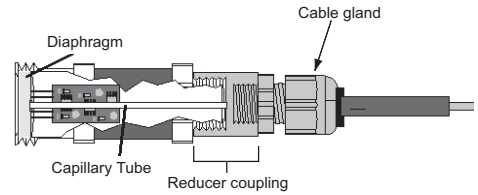

Important Installation Recommendations

- The ceramic diaphragm is subject to breakage by over-pressure conditions or mechanical contact. **HANDLE WITH CARE.** Do not attempt to test the sensor by pressing on the diaphragm.
- Short duration pressure pulses or shocks, called “water hammer” are generated by a rapid change in flow rate caused by the operation of system components such as compressors, pumps, pistons and valves. Water hammer can reach pressure levels far exceeding the over pressure rating of our pressure sensors and damage the ceramic diaphragm.
- A pressure snubber is a device for slowing the rate of change of system flow. Installation of a properly sized snubber at or near the input of a pressure sensor will protect it from water hammer damage. Snubbers are available through plumbing and instrumentation dealers.
- When threading the sensor into a piping system, any backpressure can damage the ceramic diaphragm. Open nearby valves to relieve any backpressure while threading the sensor into the pipe.
- If the nearby valves cannot be open while threading the sensor into the pipe, a bleed valve can be installed to avoid over pressure.
- Make sure there are no air bubbles in the pipe, particularly if a long and flexible hose is used to tap into the process pipe. Air bubbles could cause reading fluctuation and errors.

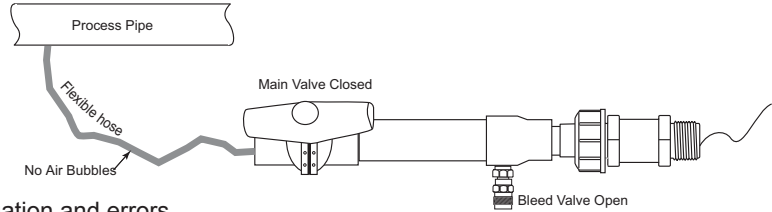

The compact integral assembly can be assembled by using the following directions:

3.1 Integral Assembly Sensor Modification

- Modify sensor part number 3-2450 per figure 1.
- Apply sealant or PTFE tape to the process connection threads per figure 2, after inspecting threads to ensure integrity. Do not install a sensor with damaged threads.
- Thread the sensor into the 3-8052 mounting kit.
- Tighten the sensor 1½ turns past finger tight into the process connection.
- Install 8450 transmitter (refer to 8450 manual for wiring info).
- The 3-8052 Integral kit includes:
 - ¾ in. NPT process connection
 - 3-9000.392-1 liquid tight connector, ½ in. NPT
 - Conduit base to attach 8450.

Integral assembly

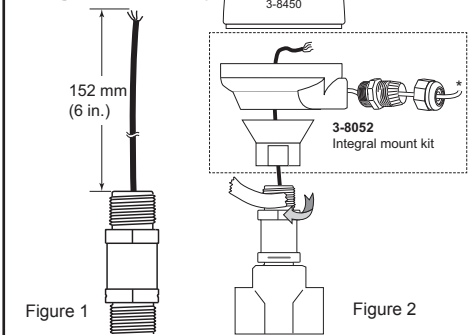

3.2 In-line Remote Assembly

The optional 3-8052-1 Integral Junction box with ¾ in. process connection offers a convenient terminal point to extend the 2450 cable over a distance greater than 4.6 m (15 ft).

- The kit includes:
 - ¾ in. NPT process connection
 - Conduit base and cap with junction terminals
 - 3-9000.392-1 liquid tight connector, ½ in. NPT

To extend the wires longer than 4.6 m (15 ft)

- Modify sensor 3-2450 as described in figure 1.
- Terminate the three wires to the terminal board located in the cap assembly.
- Add customer supplied wire to extend the cable.
- Terminate to the transmitter or the 4 to 20 mA input device.
- Apply sealant or PTFE tape to the process connection threads per figure 3, after inspecting threads to ensure integrity. Do not install a sensor with damaged threads.
- Tighten the sensor 1½ turns past finger tight into the process connection.

Remote assembly

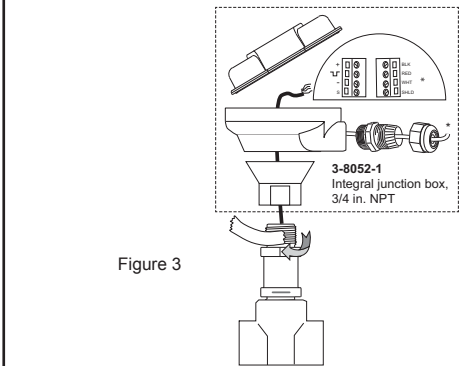

3.3 Tank Installation Options

Submersible:

- Refer to the GF product 3-2250-XX for submersible installations. (Refer to Signet Submersion Kit 3-0000.707)

Side Tank Mount:

- Install GF ball valve to allow isolation of the sensor for maintenance.
- It is recommended that a 3-8052-1 kit be used to protect the back end of the sensor.

WARNING: Exposing the sensor body to elevated temperature that are different than the tank fluid temperatures will cause inaccurate reading.

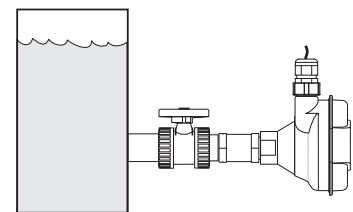

3.4 1/2 Inch Male Union Installation

- The 2450-3X, the 2450-4X and the 2450-7X sensors have a union-style process connection. To assemble:
 - Slide union nut onto pipe or flexible tubing.
 - Install end connectors.
 - Hand-tighten union nut to secure.
 - A 3/4 in. NPT thread is provided to attach a cable gland or conduit.
 - Refer to Signet Measurement and Instrumentation Product Catalogue (page 205) for ordering information.

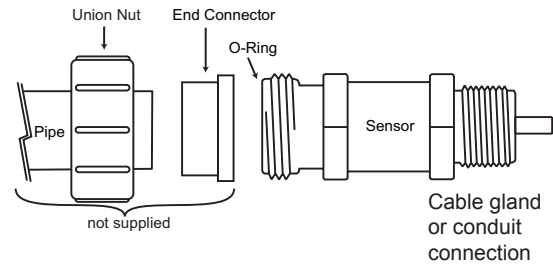

4. Digital (S³L) wiring

- All models of the 2450 provide Digital (S³L) output when powered with 5 VDC.
- Connecting the SHIELD to a direct Earth ground may reduce electrical noise interference.
- The maximum Digital (S³L) cable length is dependent upon the instrument to which the sensor is connected. Consult the instrument manual for details.

4.1 Digital (S³L) With No Junction Box

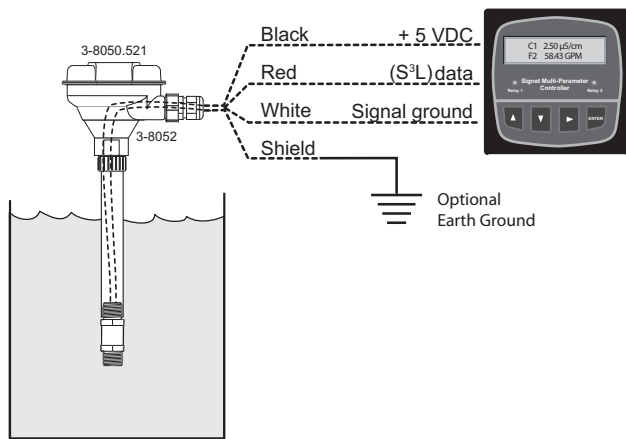

- Connect the 2450 cable directly to Digital (S³L) I/O terminals.

4.2 Digital (S³L) With Junction Box

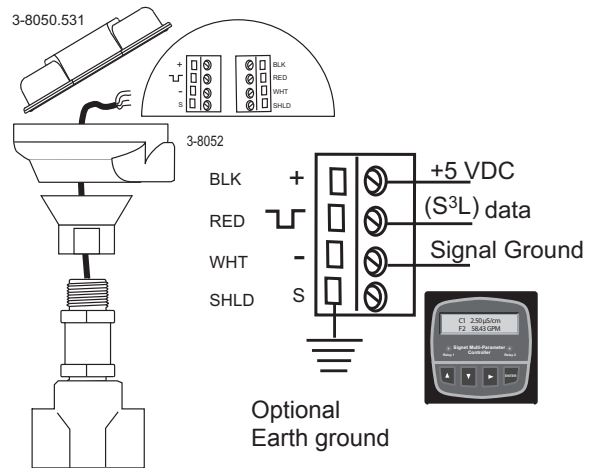

- When the 2450 includes a junction box, connect the 2450 terminals to any Digital (S³L) I/O port as shown.

5. 4 to 20 mA Loop Wiring

- The 2450-5X and 2450-7X models provide a 4 to 20 mA loop output when powered with 24 VDC.
- Connecting the SHIELD to a direct Earth ground may reduce electrical noise interference.
- Red wire is not used, do not remove the heat shrink. See Section 6, 4 to 20 mA span adjustment.

5.1 Current Loop With No Junction Box

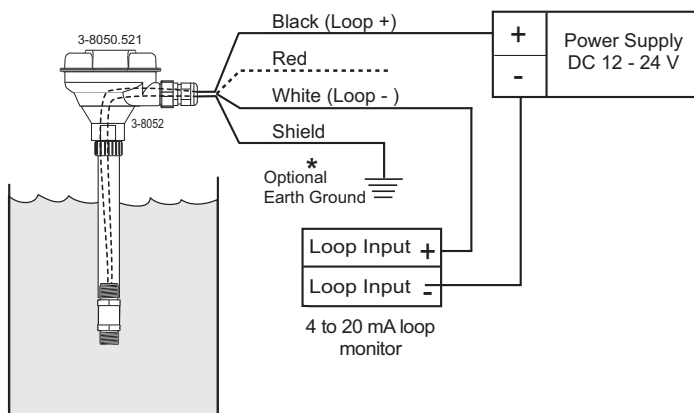

- Connect the 2450 cable directly to a loop device as shown.

5.2 Current Loop With Junction Box

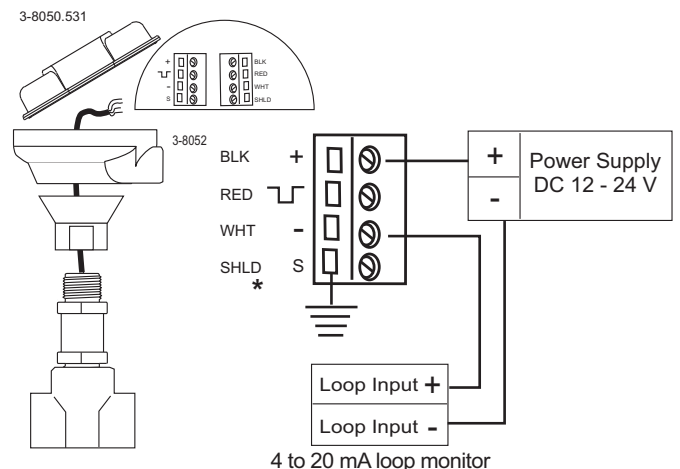

*Optional Earth ground

- When the 2450 includes a junction box, connect the 2450 terminals to the loop device as shown.

6. 4 to 20 mA Span Adjustment

The 4 to 20 mA endpoint values are independent of one another and may be adjusted in the field. For example, to reduce the 20 mA endpoint value from the maximum full scale limit set at the factory, but to allow the 4 mA endpoint to remain at 0 psig, perform only the steps listed in 6.2 below. NOTE: The RED wire, which is not connected during normal 4 to 20 mA operation, assumes an important role in the following procedures.

6.1 To adjust the 4 mA endpoint in the field:

- Carefully remove the heat shrink tube that is protecting the red wire.
- Expose the sensor to the pressure desired to correspond with 4 mA (any pressure in the operating range).
- With power applied as described in Section 5, connect the RED wire to the WHITE wire for 15 seconds. (After about 10 seconds the output will drop to 3.6 mA and remain there until the RED wire is disconnected.)
- Disconnect the RED wire from the WHITE wire; the 4 mA endpoint has been adjusted.

NOTE: The output will act as a switch if the 4 and 20 mA endpoints are set very near to the same value.

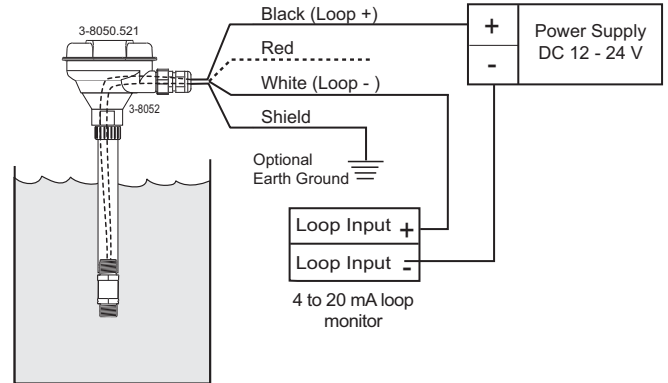

6.2 To adjust the 20 mA endpoint in the field:

- Expose the sensor to the pressure desired to correspond with 20 mA (any pressure in the operating range).
- With power applied as described in Section 5, connect the RED wire to the BLACK wire for 15 seconds. (After about 10 seconds the output will rise to 22 mA and remain there until the RED wire is disconnected.)
- Disconnect the RED wire from the BLACK wire; the 20 mA endpoint has been adjusted.

NOTE: The output will act as a switch if the 4 and 20 mA endpoints are set very near to the same value.

Minimum span is $\pm 2\%$ of maximum range.

- After adjusting the 4 to 20 mA span, protect the red wire by installing the provided wire nut.
- For easier re-spanning use the Signet 0250 USB to Digital (S³L) Configuration/Diagnostic Tool.

6.3 To restore factory span:

- Disconnect power to the sensor. Wait 10 seconds to allow circuit to discharge.
- Connect the RED wire to the WHITE wire.
- Apply power as described in Section 5, but with the RED wire connected to the WHITE wire for 15 seconds. (After about 10 seconds the output will drop to 3.6 mA and remain there until the RED wire is disconnected.)
- Disconnect the RED wire from the WHITE wire; factory settings have been restored.

Mfr. Part No.	Factory Span
3-2450-7U	4 to 20 mA = 0 to 10 psig
3-2450-5L	4 to 20 mA = 0 to 50 psig
3-2450-7L	4 to 20 mA = 0 to 50 psig
3-2450-5H	4 to 20 mA = 0 to 250 psig
3-2450-7H	4 to 20 mA = 0 to 250 psig



7. Ordering Information

Mfr. Part No.	Code	Description
3-2450-3U	159 000 683	10 psig, Digital (S ³ L), 1/2 in. Male Union, 15 ft Cable
3-2450-7U	159 000 906	10 psig, 4 to 20 mA, 1/2 in. Male Union, 15 ft Cable
3-2450-1L	159 000 024	50 psig, Digital (S ³ L), 3/4 in. NPT, 15 ft Cable
3-2450-3L	159 000 682	50 psig, Digital (S ³ L), 1/2 in. Male Union, 15 ft Cable
3-2450-5L	159 000 907	50 psig, 4 to 20 mA, 3/4 in. NPT, 15 ft Cable
3-2450-7L	159 000 908	50 psig, 4 to 20 mA, 1/2 in. Male Union, 15 ft Cable
3-2450-1H	159 000 026	250 psig, Digital (S ³ L), 3/4 in. NPT, 15 ft Cable
3-2450-3H	159 000 681	250 psig, Digital (S ³ L), 1/2 in. Male Union, 15 ft Cable
3-2450-5H	159 000 909	250 psig, 4 to 20 mA, 3/4 in. NPT, 15 ft Cable
3-2450-7H	159 000 910	250 psig, 4 to 20 mA, 1/2 in. Male Union, 15 ft Cable
3-8050-1	159 000 753	Universal Mount Junction Box
3-8052-1	159 000 755	3/4 in. NPT mount junction box
3-9000.392-1	159 000 839	Liquid tight connector kit, NPT (1 piece)
3-9000.392-2	159 000 841	Liquid tight connector kit, PG 13.5 (1 piece)
5523-0322	159 000 761	Cable, 3 conductor + shield, 22 AWG, black/red/white/shield
3-0250	159 001 538	USB to digital (S ³ L) configuration/diagnostic tool



Georg Fischer Signet LLC, 3401 Aerojet Avenue, El Monte, CA 91731-2882 U.S.A. • Tel. (626) 571-2770 • Fax (626) 573-2057
 For Worldwide Sales and Service, visit our website: www.gfsignet.com • Or call (in the U.S.): (800) 854-4090
 For the most up-to-date information, please refer to our website at www.gfsignet.com