



3-8860.090

Rev. F 2/08 English



## CAUTION!

- Remove power to unit before wiring input and output connections.
- Follow instructions carefully to avoid personal injury.
- This product should only be used for the purposes and in the manner described in this manual.

## Installation

1. Punch out panel and de-burr edges. Recommended clearance on all sides between instruments is 1 inch.
2. Place gasket on instrument, and install in panel.
3. Slide mounting bracket over back of instrument until quick-clips snap into latches on side of instrument.
4. Connect wires to terminals.
5. To remove, secure instrument temporarily with tape from front or grip from rear of instrument. DO NOT RELEASE. Press quick-clips outward and remove.
6. If cleaning is necessary, wipe the front of the unit with a damp cloth.
7. The live contacts on the back of this unit must be covered to avoid accidental shock hazard.

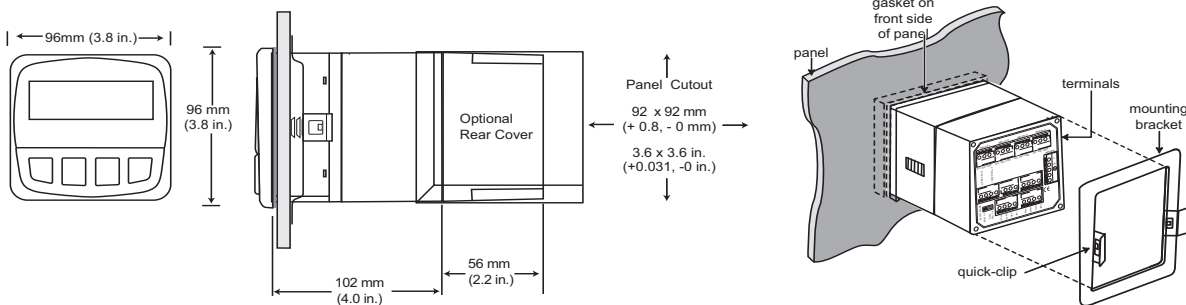

## Specifications

### General

Compatible electrodes: Signet 2819 to 2823 (Standard or Certified Cond/Resist Sensors)

### Enclosure:

- Rating: NEMA 4X/IP65 front (NEMA 4X Rear cover available)
- Case: PBT
- Panel case gasket: Neoprene
- Window: Polyurethane-coated polycarbonate
- Keypad: Sealed 4-key silicone rubber
- Weight: 8860-AC: 1.28 lb/0.58 kg    8860: 1.2 lb/0.55 kg

### Display (Alphanumeric 2 x 16 LCD) :

- Contrast: User selected, 5 levels
- Update rate: 1.5 seconds

### Sensor input range:

- Conductivity: 0.01  $\mu\text{S}/\text{cm}$  to 400 000  $\mu\text{S}/\text{cm}$
- Resistivity: 10  $\text{K}\Omega\cdot\text{cm}$  to 100  $\text{M}\Omega\cdot\text{cm}$
- TDS: 0.023 to 200 000 PPM nominal (adjustable  $\mu\text{S}/\text{PPM}$ )
- Temperature: -25 to 120°C (-13 to 248°F) PT 1000; 25°C = 1096 $\Omega$

### Accuracy:

- Conductivity/Resistivity:  $\pm 2\%$  of reading
- Temperature:  $\pm 0.5^\circ\text{C}$  (0 to 100°C)

### Electrical

#### Power requirements:

3-8860-AC: 100 to 240 VAC  $\pm 10\%$ , 50-60 Hz, 20VA or 11 to 24 VDC  $\pm 10\%$ , regulated, 0.5 A max

3-8860: 11 to 24 VDC  $\pm 10\%$ , regulated, 0.5 A max

#### Three 4 to 20 mA Outputs:

- Passive, isolated, fully adjustable and reversible  
4 to 20 mA outputs are independently source selectable
- Max loop impedance:  
150  $\Omega$  @ 12 V, 450  $\Omega$  @ 18 V, 750  $\Omega$  @ 24 V
- Update rate:  $\sim 100$  ms
- Accuracy:  $\pm 0.03$  mA @ 25°C, 24 VDC

#### Open-collector outputs (2 available, optically isolated):

- 50 mA sink or source, 30 VDC max. pull-up voltage
- Programmable for:
  - High or Low setpoint with adjustable hysteresis
  - Pulse operation (max. rate: 400 pulses/min)
  - USP standards
  - Time delay: 0 to 6400 s.

#### Relay outputs (up to 4 SPDT relays available)

- Maximum resistive load: 5 A @ 250 VAC, 5 A @ 30 VDC
- Isolation between open contacts: 500 V minimum
- Programmable for:
  - High or Low setpoint with adjustable hysteresis
  - Pulse operation (max. rate: 400 pulses/min)
  - USP standards
  - Time delay: 0 to 6400 s

### Environmental

- Ambient operating temperature: -10 to 55°C (14 to 131°F)
- Storage temperature: -15 to 80°C (5 to 176°F)
- Relative humidity: 0 to 95%, non-condensing
- Maximum altitude: 2000 m (6562 ft)
- Insulation category: II
- Pollution degree: 2

### Standards and Approvals

- CE
  - EN61326: Immunity & Emissions for Control Equipment
  - EN61010: Safety
- UL listed
- Manufactured under ISO 9001, ISO 14001

- Chinese RoHS

For detailed information go to [www.gfsignet.com](http://www.gfsignet.com)

# Electrical Connections

 **Caution:** Failure to fully open terminal jaws before removing wire may permanently damage instrument. This product must be provided with a means to disconnect all current carrying conductors connected to the main AC line, or, as part of the building installation.

## Wiring Procedure

1. Remove 0.35- 0.47 in. (9-12 mm) of insulation from wire end.
2. Press the orange terminal lever downward with a small screwdriver to open terminal jaws.
3. Insert exposed (non-insulated) wire end in terminal hole until it bottoms out.
4. Release orange terminal lever to secure wire in place. Gently pull on each wire to ensure a good connection.

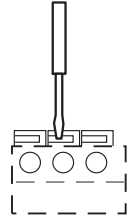

## Wiring Removal Procedure

1. Press the orange terminal lever downward with a small screwdriver to open terminal jaws.

## Wiring Tips:

- Do not route sensor cable in conduit containing AC power wiring - electrical noise may interfere with sensor signal.
- Routing sensor cabling in grounded metal conduit may prevent moisture damage, electrical noise, and mechanical damage.
- Seal cable entry points to prevent moisture damage.
- Do not insert two wires into a single terminal. If necessary, splice the wires together before inserting into the terminal.



**Caution:**  
**Electrical shock hazard exists!**

Never connect live AC lines to the instrument.

Always connect a ground wire to the ground terminal when using AC power.

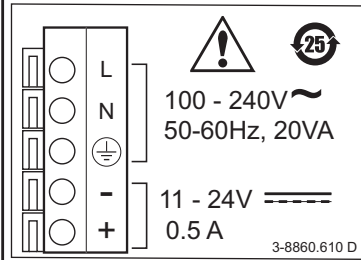
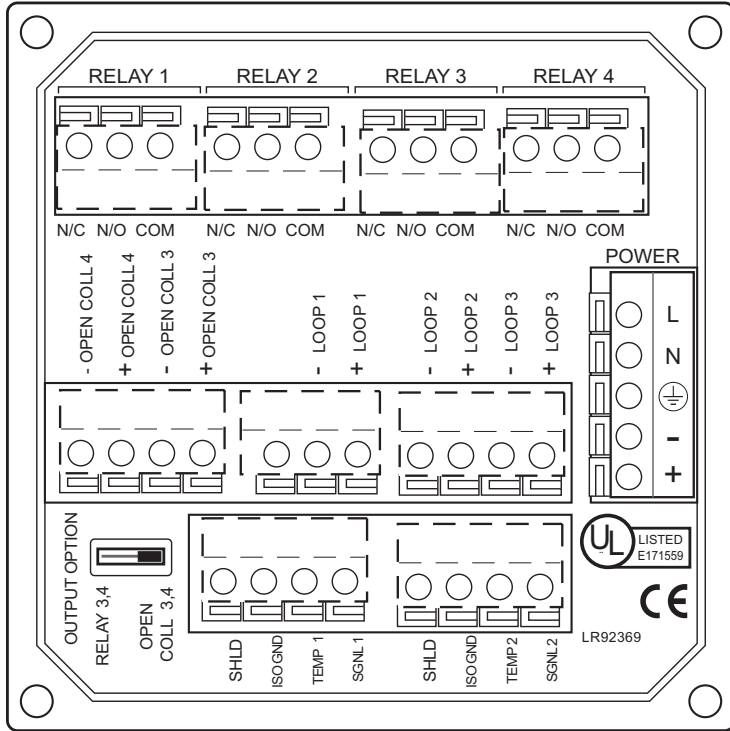

## 4 to 20 mA loop Outputs

The current loops in the 8860 are passive circuits. 12-24 VDC must be provided from an external source. A single loop is illustrated for clarity.

## Output Option Switch

- In OPEN COLLECTOR position, relays 3 and 4 are open collector outputs as shown.
- In RELAY 3, 4 position, relays 3 and 4 are dry contact relays identical to relays 1 and 2.
- The menu references in the 8860 display will not change. Outputs 3 and 4 will be identified as "Relay" regardless of switch setting.

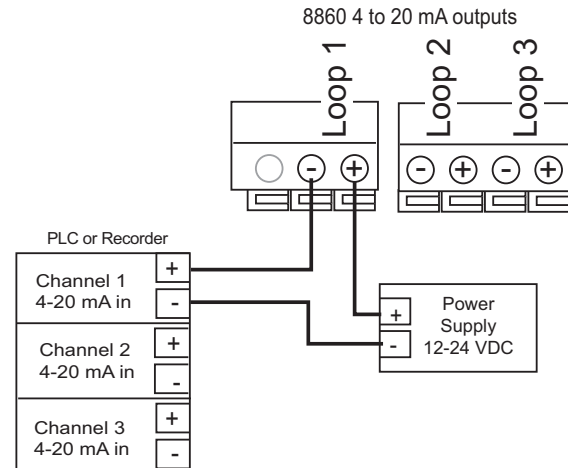
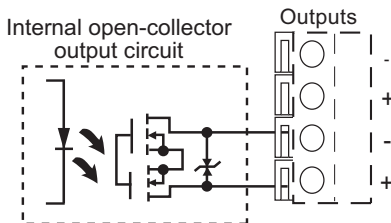

# Sensor Input Connections

- The 8860 will accept two independent sensor input signals. The two sensors may be of different cell constant values.
- Do not route sensor cable in any conduit containing AC power wiring - electrical noise may interfere with the signal.
- Cable shield MUST be maintained through cable splice.
- Use three conductor shielded cable for cable extensions up to 30 m (100 ft) max. for measurements below 10 MΩ (above 0.10 μS).
- Maximum cable length for resistivity measurements above 10 MΩ is 25 ft, and solution temperatures must be between 20°C and 100°C.

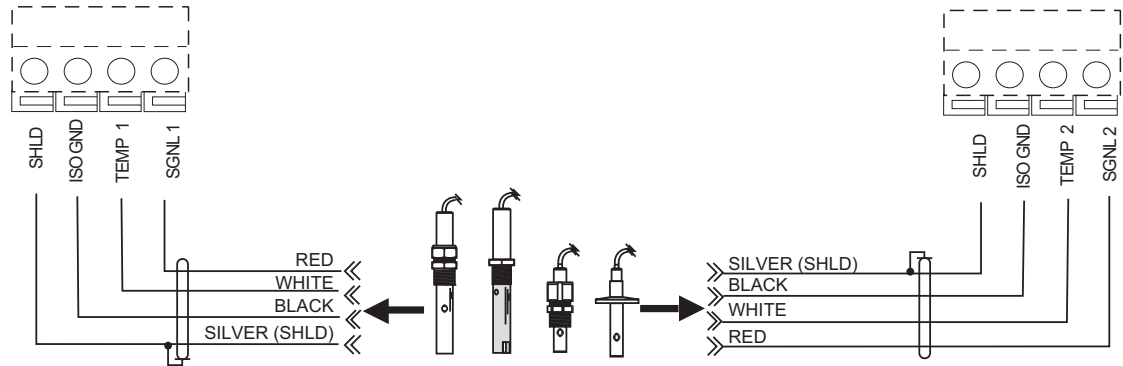
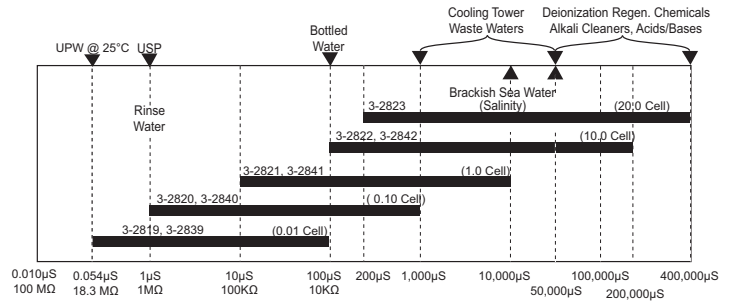

## Relay and Open Collector Functions

The 8860 is equipped with 4 SPDT relays that can be configured for High alarm, Low alarm, Proportional pulse or USP operation.

- **Low:** Output triggers when process variable is less than setpoint.
- **High:** Output triggers when process variable is higher than setpoint.
- **Off:** Disables output pulse.

## Pulse Operation

The output emits a 100 mS pulse at a rate defined by the Source, Pulse Range and Max PlsRate settings, and by the process condition. The maximum pulse rate is 400 pulses per minute.

Example: As the process falls below 10 μS the output will start pulsing in relation to the process value, the max pulse endpoint and the programmed pulses/min. Pulse rate will increase as the process approaches the programmed endpoint.

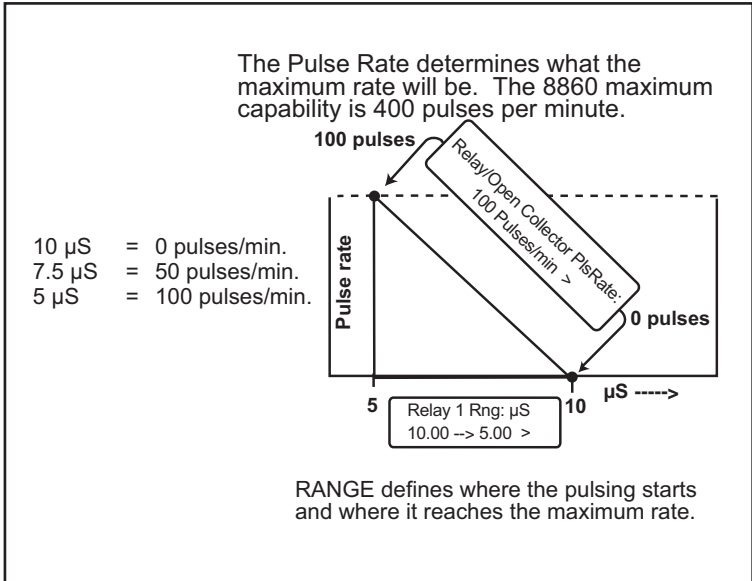
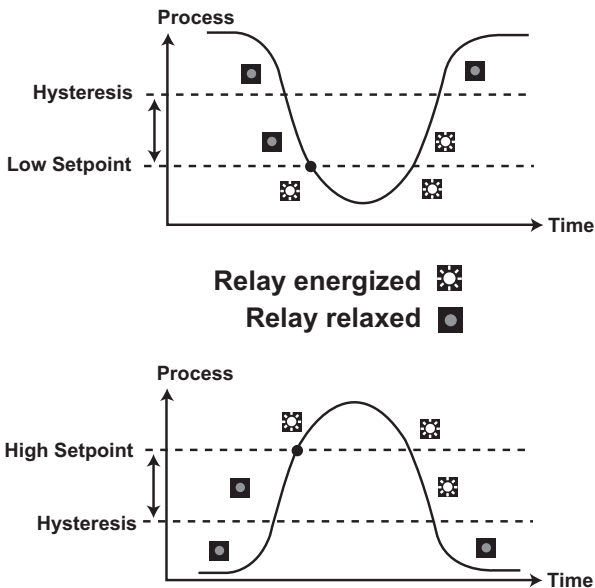

# VIEW menu

- During normal operation, the ProcessPro displays the VIEW menu.
- When using the CALIBRATE or OPTIONS menus, the ProcessPro will return to the VIEW menu if no activity occurs for 10 minutes.
- To select the item you want displayed, press the UP or DOWN arrow keys. The items will scroll in a continuous loop. Changing the display selection does not interrupt system operations.
- No keycode is necessary to change display selection.
- Output settings cannot be edited from the VIEW menu.



## View Menu

Display	Description
C1 1000.00 μS/cm C2 30.00 μS/cm	Monitor C1 Conductivity and C2 Conductivity simultaneously. This is the permanent display when Channel 2 is ON.
C1 1000.00 μS/cm 25.0 °C	Monitor Channel 1 Conductivity and Channel 1 Temperature. This is the permanent display when Channel 2 is OFF.

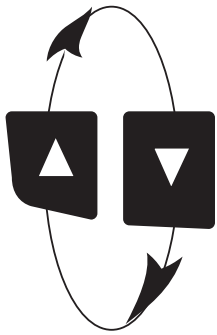

The VIEW displays below are temporary. The permanent display will return after 10 minutes

C2 30.00 μS/cm 25.0 °C	Monitor Channel 2 Conductivity and Channel 2 Temperature. This view is available only when Channel 2 is ON.
Reject C1 → C2 97.00	Monitor Percent Reject, Difference, or Ratio (Channel 1 to Channel 2 or Channel 2 to Channel 1)
Loop 1 12.03 mA Loop 2 5.69 mA	Monitor Loop 1 and Loop 2 current output simultaneously.
Loop 3 13.7 mA R3 ON R4 PLS	Monitor Loop 3 and status of Relays 3 and 4 (Open Collector 3 and 4).
Last Cal 04-20-08	Monitor date for scheduled maintenance or date of last calibration.

# ProcessPro Editing Procedure:

## Step 1. Press and hold ENTER key:

- 2 seconds to select the CALIBRATE menu.
- 5 seconds to select the OPTIONS menu.

## Step 2. The Key Code is UP-UP-UP-DOWN keys in sequence.

- After entering the Key Code, the display will show the first item in the selected menu.

## Step 3. Scroll menu with UP or DOWN arrow keys.

## Step 4. Press RIGHT ARROW key to select menu item to be edited.

- The first display element will begin flashing.

## Step 5. Press UP or DOWN keys to edit the flashing element.

- RIGHT ARROW key advances the flashing element.

## Step 6. Press ENTER key to save the new setting and return to Step 3.

### Notes on Step 1:

- The View Menu is normally displayed.
- The CALIBRATE and OPTIONS menus require a KEY CODE.

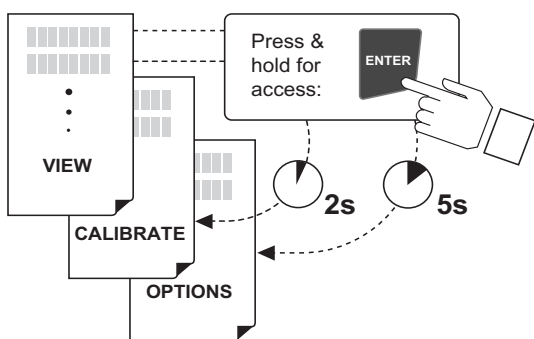

### Notes on Step 2:

If no key is pressed for 5 minutes while display is showing "Enter Key Code", the display will return to the VIEW menu.

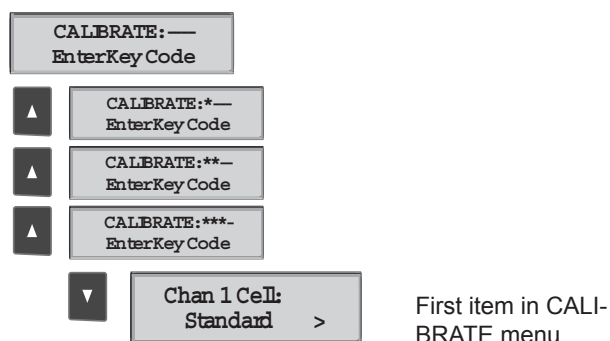

### Notes on Steps 3 and 4:

- Refer to pages 6 and 7 for complete listing of menu items and their use.
- From the Step 3 display, pressing the UP and DOWN keys simultaneously will return the display to the VIEW menu.
- If no key is pressed for 10 minutes, display will also return to the VIEW menu.

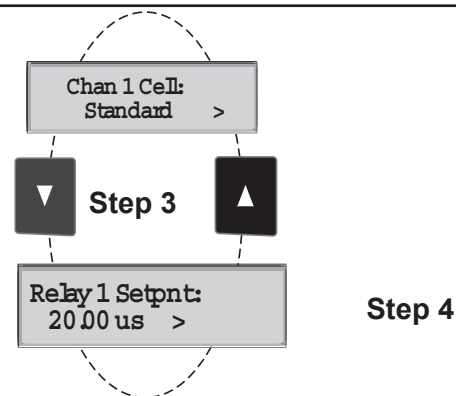

### Step 3: Finished Editing?

Press the UP and DOWN keys simultaneously after saving the last setting to return to normal operation.

### Notes on Steps 5 and 6:

- All output functions remain active during editing.
- Only the flashing element can be edited.
- RIGHT ARROW key advances the flashing element in a continuous loop.
- Edited value is effective immediately after pressing ENTER key.
- If no key is pressed for 10 minutes unit will restore the last saved value and return to step 3.
- Step 6 (pressing ENTER key) always returns you to Step 3.
- Repeat steps 3-6 until all editing is completed.

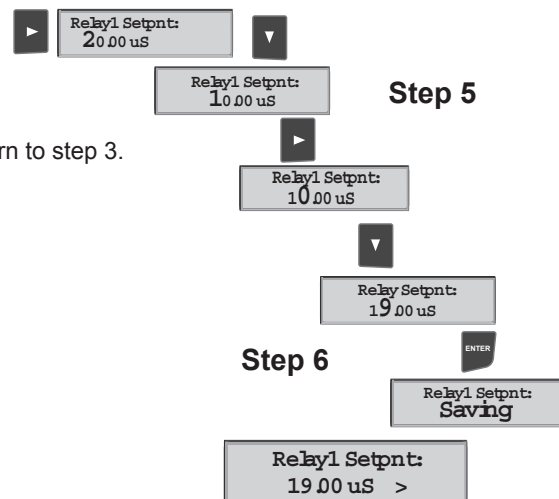

### Step 5: Made an Error?

Press the UP and DOWN keys simultaneously while any element is flashing. This will recall the last saved value of the item being edited and return you to Step 3.



## Calibrate Menu

Display (Factory settings shown)	Description
Chan 1 Cell: Standard >	Select CUSTOM only if you are connecting a certified conductivity sensor. Select STANDARD for all non-certified sensors.
Chan 1 Cell: 1.0 >	For STANDARD sensors: Select the nominal cell constant: 0.01, 0.1, 1.0, 10.0 or 20.0.
Cell: Custom 1.0000 >	For CUSTOM sensors: Enter the precise cell constant from the certificate provided with your sensor, or from the information label on the sensor.
Chan 1 Set: Temperature >	Adjust the temperature of the system based on an accurate external reference.
Chan 1 Set: Conductivity >	This single-point wet calibration procedure requires a test solution of known value. Enter all zeroes here to restore TEMPERATURE and CONDUCTIVITY to factory calibration.
Chan 1 Units: uS/cm >	Select the units of measure: $\mu\text{S}/\text{cm}$ , $\text{mS}/\text{cm}$ , $\text{k}\Omega\cdot\text{cm}$ , $\text{M}\Omega\cdot\text{cm}$ , PPB, PPM
Chan 1 TDS: 2.0000 uS/PPM >	If the Units selection is PPM or PPB, set the ratio of $\mu\text{S}$ to Total Dissolved Solids. The factory preset value is 2 $\mu\text{S}$ per 1 PPM of TDS. (Always $\mu\text{S}/\text{PPM}$ , even if units is PPB). See page 10 for additional information.
Function: Reject C1 $\rightarrow$ C2 >	Select a functional relationship between C1 and C 2: <ul style="list-style-type: none"> <li>• Ratio is (C1:C2) or (C2:C1)</li> <li>• Percent Reject is 100%(1-C2/C1) or 100%(1-C1/C2)</li> <li>• Difference is (C1-C2) or (C2-C1)</li> </ul>
Loop 1 Source: Chan 1 Cond >	Select the measured value or calculated FUNCTION you want Loop 1 to represent: Chan 1 Cond, Chan 2 Cond, Chan 1 Temp, Chan 2 Temp, or Function
Loop 1 Range: uS 0.0000 $\rightarrow$ 100.000 >	Set the minimum (4 mA =) and maximum (20 mA =) range for Loop 1. Make sure that the values are consistent with the units of the source.
Relay 1 Mode: Low >	Select operating mode for Relay 1: OFF, LOW, HIGH, USP or PULSE. For USP mode: <ul style="list-style-type: none"> <li>• Relay 1 SOURCE <u>must be</u> Cond 1 or Cond 2</li> <li>• Temp Comp (Options menu) <u>must be</u> set to None</li> </ul>
Relay 1 Source: Chan 1 Cond >	Select the INPUT SIGNAL (or FUNCTION) monitored by Relay 1: <ul style="list-style-type: none"> <li>• Cond 1</li> <li>• Cond 2</li> <li>• Temp 1</li> <li>• Temp 2</li> <li>• Function</li> </ul>
Relay 1 Setpnt: 10.0000 uS >	Set Relay 1 activation point. The maximum value acceptable is 999999. USP setpoints are high alarms, where the setpoint is a percentage below the USP limit.
Relay 1 Hys: 0.5000 uS >	Relay 1 will be deactivated at setpoint $\pm$ Hysteresis (depending on High or Low selection). When the relay Mode is USP (defined as a HIGH alarm), Hysteresis is displayed in $\mu\text{S}$ .
Relay 1 Delay: 10.0 secs >	Set up to 6400 seconds delay time for relay response. Relay 1 will be activated only if the source value exceeds the setpoint for this time period.
Relay 1 Rng: uS 10.0000 $\rightarrow$ 40.0000 >	If Relay 1 is PULSE mode, set the start and end point of the conductivity range and also set the maximum pulse rate. (The maximum PULSE rate setting is 400 pulses per minute.)
Relay 1 PlsRate: 120 Pulses/Min >	The combined Relay 1 Range and Pulse rate settings shown here indicate: "Start pulsing when the conductivity value is 10 $\mu\text{S}$ and increase the pulse rate up to the maximum of 120 pulses per minute when the conductivity value reaches 40 $\mu\text{S}$ "
Last CAL: 04-20-08 >	Use this "notepad" to record important dates, such as annual recertification or scheduled maintenance.

- All changes in this menu become effective when saved, except the "Set Cond" and "Set Temp" settings.
- All outputs affected by a change in the "Set Cond" and "Set Temp" settings are frozen until you exit the Calibrate menu.

## USP Limits

USP (United States Pharmacopoeia) has defined a set of conductivity values (limits) to be used for pharmaceutical water monitoring. This standard requires non-temperature compensated conductivity measurement be used to warn if the conductance approaches the USP limit. The limits vary according to the temperature of the sample.

The 8860 has the USP limits stored in memory. It will automatically determine the proper USP limit based on the measured temperature.

## Using the USP function

In the 8860, USP setpoints are defined as a percentage below the USP limit, so a USP alarm is always a HIGH alarm. The 8860 can be set to warn you if the conductivity approaches within a set percentage of the USP limit.

### The following settings and conditions are required for a USP relay function:

1. In the CALIBRATE menu:
  - RELAY MODE must be set to **USP**.
  - RELAY SOURCE must be **Chan 1 or Chan 2 Cond**.
  - SOURCE UNITS must be set to **µS**.
2. In the OPTIONS menu:
  - The TC Mode of the USP channel must be set to **None**.

**(Service tip: If a relay is constantly on when it should be off, check the relay settings listed above.)**

### Example:

- The USP setpoint is 40%.
- The water temperature is 19°C, so the USP limit is 1.0 µS.
- The relay will be activated when the conductivity value reaches 0.6 µS, or 40% below the 1.0 USP limit.
- If the water temperature drifts to more than 20°C, the 8860 will automatically adjust the USP limit to 1.1.
- The relay will now be activated when the conductivity value reaches 40% below 1.1 µS, or 0.66 µS.

When the temperature range is:	The USP limit (µS) is:
0 to < 5°C	0.6
5 to < 10°C	0.8
10 to < 15°C	0.9
15 to < 20°C	1
20 to < 25°C	1.1
25 to < 30°C	1.3
30 to < 35°C	1.4
35 to < 40°C	1.5
40 to < 45°C	1.7
50 to < 55°C	1.8
55 to < 60°C	2.1
60 to < 65°C	2.2
65 to < 70°C	2.4
70 to < 75°C	2.5
75 to < 80°C	2.7
80 to < 85°C	2.7
85 to < 90°C	2.7
90 to < 95°C	2.7
95 to < 100°C	2.9
100 to < 105°C	3.1



## Options Menu

Display (Factory settings shown)	Description
<b>Contrast:</b> 3 >	Adjust the LCD contrast for best viewing. A setting of 1 is lower contrast, 5 is higher. In general, select lower contrast if the display is in warmer ambient surroundings.
<b>Temp Display:</b> °C >	Select °C or °F.
<b>Channel 2:</b> On >	Turn CH 2 OFF if not in use. This will remove all menu functions related to CH 2.
<b>Power:</b> 60 Hz >	Select 50 Hz or 60 Hz electrical noise suppression, according to the AC power used in your area. Select the proper setting for all applications, whether AC or DC powered.
<b>Chan 1 TC Mode:</b> Linear >	Set the method for temperature compensation to NONE, LINEAR or PURE WATER. You must select NONE for USP systems. Select LINEAR for applications where the water is less than 5 MΩ (or greater than 0.2 μS). Select PURE WATER for applications where the water is greater than 5 MΩ (or less than 0.2 μS).
<b>Chan 1 TC Slope:</b> 0.00 % >	For LINEAR or PURE WATER temperature compensation, select a % per °C slope. Maximum slope setting is 9.99 % per °C. If Temp Comp setting is NONE, this item will not be displayed.
<b>Averaging:</b> Off >	OFF provides the most instantaneous response to process changes. Select LOW (4 sec) or HIGH (8 sec) averaging if your process experiences frequent or extreme fluctuations.
<b>Chan 1 Decimal:</b> *,**** >	Set the decimal to the best resolution for your application. The display will automatically scale up to this restriction. Select *****, ***, **, * or .
<b>Loop 1 Adjust:</b> 4.00 mA >	Adjust the minimum and maximum current output. The display value represents the precise current output. Adjustment limits: • 3.80 mA < 4.00 mA > 5.00 mA • 19.00 mA < 20.00 mA > 21.00 mA Use this setting to match the system output to any external device. These settings repeat for Loop 2 and Loop 3.
<b>Loop 1 Adjust:</b> 20.00 mA >	
<b>Relay 3 Active:</b> High >	Select active HIGH or active LOW operation for relay 3 Recommended: Use active LOW if OUTPUT OPTION switch is set for OPEN COLLECTOR operation. Active HIGH: Power is applied to relay coil when process value reaches SETPOINT. Active LOW: Power is removed from relay coil when process value reaches SETPOINT.
<b>Test Loop 1:</b> >	Press UP and DOWN keys to manually change Loop 1 output current. Limits are 3.6 mA to 21.00 mA. Hold UP or DOWN keys to scroll the output value.
<b>Test Relay 1:</b> >	Press UP and DOWN keys to manually toggle the relay state.

### Notes:

Channel settings will repeat when Channel 2 is enabled.

Loop settings will repeat for Loop 2 and Loop 3.

Check setting for related values when making changes (for example, if temp is set for °C with a temp alarm at 25°C, and you change the temp to °F, be sure to change the alarm setpoint to 77°F.)

Relay settings will repeat for Relays 2, 3 and 4 (except "Relay Active" selection; applies to Relay 3 and 4 only.)



## Calibration Procedure

The 8860 has been electronically calibrated at the factory.

- Procedure A verifies the accuracy and linearity of the 8860 by simulating temperature and conductivity values with precision ( $\pm 0.1\%$ ) fixed resistors.
- Procedure B is a wet calibration. This procedure uses the sensor input and NIST traceable test solutions.

### A) Accuracy Verification with Precision Resistors (Electronic Calibration):

#### 1. Simulate the Temperature

The temperature input to the 8860 is a PT-1000 thermistor, where 1000 Ohms ( $\Omega$ ) is equal to  $0^\circ\text{C}$  and a change of  $3.84 \Omega$  equals a  $1^\circ\text{C}$  change. ( $1000 \Omega = 0^\circ\text{C}$ ,  $1003.84 \Omega = 1.0^\circ\text{C}$ ,  $1007.68 \Omega = 2.0^\circ\text{C}$ ..... $1096 \Omega = 25^\circ\text{C}$ )

- Connect a resistor ( $1000 \Omega$  to  $1096 \Omega$ ) between "Temp" and "Iso. Gnd" terminals.
- Set Temp; Adjust the temperature to exact value based on the measured resistance. (See Editing Procedure, Calibrate menu).
- To verify the 8860 temperature linearity, connect a second resistor value to the terminals.
- If the 8860 does not display the correct value, service is required. ( $\pm 0.5^\circ\text{C}$ )

#### 2. Simulate the Conductivity

You may calculate the exact Resistance needed to simulate a specific conductivity value, or you may calculate the exact Conductivity based on a resistor value:

$$\text{Resistance} = \frac{\text{Cell constant}}{\text{conductivity (Siemens*)}} \quad \text{e.g.} \quad \frac{0.1 \text{ Cell}}{0.000020 \text{ (Siemens*)}} = 5,000 \Omega \text{ or } 5 \text{ K}\Omega$$

$$\text{Conductivity} = \frac{\text{Sensor cell}}{\text{Simulation resistance } (\Omega)} \quad \text{e.g.} \quad \frac{0.1 \text{ Cell}}{100,000 (\Omega)} = 0.000001 \text{ Siemens*} \text{ or } 1 \mu\text{S/cm}$$

(\* $1 \mu\text{S} = 1 \times 10^{-6}$  Siemens or  $0.000001$  Siemens)

- Connect the conductivity resistor between the "Sgnl 1" and "Iso Gnd" (or Sgnl 2 and Iso Gnd) terminals.
- Set Cond: Adjust the conductivity value based on the resistor value. (See Editing Procedure and Calibrate menu).
- Verify the linearity of the 8860 by connecting a second Conductivity resistor of a different value.
- If the 8860 does not display the correct value ( $\pm 2\%$  of reading), service is required.

### B) Wet Calibration with NIST Traceable Solutions:

When using NIST traceable standards, review the temperature information provided with the test solution. Prevent contamination of the test solution. The sensor must be at the temperature specified on the test solution label.

- Remove the sensor from the system. Rinse the sensor in a small amount of test solution.
- Place the sensor into the test solution.
- Place a reference thermometer into the same solution.
- Allow sufficient time for the temperature to stabilize.
- Set Temp: Adjust the temperature value based on the reference thermometer. (See Editing Procedure.)
- Set Cond: Adjust the conductivity value based on the test solution value. (See Editing Procedure.)
- Verify the linearity of the 8860 by placing the sensor into a second test solution of a different value.
- If the 8860 does not display the correct value (Temperature  $\pm 0.5^\circ\text{C}$ , Conductivity  $\pm 2\%$  of reading), service is required.

## Temperature Effects

Conductivity measurement is highly dependent on temperature. The basic rule is that higher temperatures result in greater conductance (less resistance).

Temperature effects are expressed as the percentage of conductivity change (in  $\mu\text{S}$ ) per  $^{\circ}\text{C}$ . The conductivity value is generally referenced to  $25^{\circ}\text{C}$ . The 8860 has three temperature compensation options:

### None

USP standards for pharmaceutical waters require that the measurement be made without temperature compensation. USP limits are discussed on page 7.

### Pure Water (Standard Compensation)

This selection is used for measurements of very clean water, less than  $0.2 \mu\text{S}$ . Temperature effects are not linear in this range, so the temperature coefficient is not easily determined. This selection is recommended for all Resistivity applications measuring from  $5 \text{M}\Omega$  to  $18\text{M}\Omega$ . This selection conforms to ASTM standard D1125 and D5391.

### Linear

This selection allows you to calculate a custom temperature compensation value for Conductivity measurements in the range of  $0.2 \mu\text{S}$  and greater (Resistivity applications measuring less than  $5 \text{M}\Omega$ ). The procedure is outlined in the section on the right.

## Calculating a Linear Temperature Coefficient

1. Set TC Mode to NONE (see OPTIONS menu, page 8).
2. Heat a sample solution close to the maximum process temperature. Place sensor in the sample solution and allow several minutes for stabilization. Record the 8860 temperature and conductivity values in the spaces provided:

Displayed temperature: T1 = \_\_\_\_\_  $^{\circ}\text{C}$

Displayed conductivity: C1 = \_\_\_\_\_  $\mu\text{S}$

3. Cool the sample solution close to the minimum process temperature. Place sensor in the sample solution allowing several minutes for stabilization. Record displayed temperature and conductivity values in the spaces provided:

Displayed temperature: T2 = \_\_\_\_\_  $^{\circ}\text{C}$

Displayed conductivity: C2 = \_\_\_\_\_  $\mu\text{S}$

(A 10% change in conductivity between steps 2 and 3 is recommended.)

4. Substitute recorded readings (steps 2 and 3) into the following formula:

$$\text{TC Slope} = \frac{100 \times (C1 - C2)}{(C2 \times (T1 - 25)) - (C1 \times (T2 - 25))}$$

Example: A sample solution has a conductivity of  $205 \mu\text{S}$  @  $48^{\circ}\text{C}$ . After cooling the solution, the conductivity was measured at  $150 \mu\text{S}$  @  $23^{\circ}\text{C}$ . ( $C1 = 205$ ,  $T1 = 48$ ,  $C2 = 150$ ,  $T2 = 23$ )

The TC is calculated as follows:

$$\text{TC Slope} = \frac{100 \times (205 - 150)}{(150 \times (48 - 25)) - (205 \times (23 - 25))} = \frac{5500}{3860} = 1.42\%/^{\circ}\text{C}$$

## TDS Factor

Some industries need to display a conductivity value as Total Dissolved Solids (TDS), measured in units of parts per million (PPM) or parts per billion (PPB).

- 1 PPM is equivalent to 1 mg per liter.
- 1 PPB is equivalent to  $1 \mu\text{g}$  per liter.
- The 8860 calculates PPM or PPB by dividing the  $\mu\text{S}$  value by a TDS Factor that you define. TDS factors can vary widely, ranging from 1.50 to  $2.50 \mu\text{S}$  per PPM. Methods for establishing a TDS factor are beyond the scope of this manual.
- The 8860 will accept TDS factor values from 0.01 to 99999.9  $\mu\text{S}$  per PPM.  
(factory preset =  $2.00 \mu\text{S}$  per PPM)

**NOTE: The 8860 TDS factor must be set in PPM.**

TDS Factor = Conductivity ( $\mu\text{S}$ )  $\div$  Total dissolved solids (PPM)  
PPM = Solution conductivity ( $\mu\text{S}$ )  $\div$  TDS Factor

Example:

- Solution conductivity =  $150 \mu\text{S}$
- TDS = 80 PPM
- TDS Factor =  $150 \mu\text{S} \div 80 \text{ PPM} = 1.88 \mu\text{S per PPM}$

## Troubleshooting

Display Condition	Possible Causes	Suggested Solutions
"-----"	Display is over range. This may be a normal condition if your process operates at/near the limits of the sensor range.	Check sensor for correct range. Check Decimal setting in OPTIONS menu. Check Calibrate menu settings for incompatible SOURCE and RANGE values.
"Value Must be 100 or less"	The menu item being set is a percentage value and must be less than 100.	Select a value from 0 to 100.
"Value must be more than 0"	The menu item being set cannot be zero or a negative value.	Select a value greater than zero.
"Value must be 400 or less"	The Pulse Rate for Relay and Open Collector outputs cannot be greater than 400 pulses per minute.	Select a pulse rate less than 400
"Reset to Factory Calibration"	A value of "0" is being set into ".. Set: Conductivity" menu item.	This will remove any user calibration from the "..Set Conductivity" and "..Set Temperature" items in the Calibrate menu.
"Too Much Error CHECK SENSOR"	The calibration offset entered is beyond the allowable tolerances of the instrument.	Check calibration procedure for accuracy. Check sensor for proper operation. Check any cable extensions for poor splices or termination.

### Technical Note

If a Current Loop is locked at 3.6 mA, the problem is related to the temperature circuit:

This occurs only if the 8860 detects a resistance from the temperature sensor that is less than 250Ω or greater than 2800Ω.

- Check the sensor wiring for open/short or poor connections on white (TEMP IN) and black (ISO GND)wires.
- The PT1000 temperature device in the sensor is defective.
- The transmitter is defective.

## Ordering Information

Mfr. Part No	Code	Description
3-8860	159 000 677	Conductivity/Resistivity Controller, DC
3-8860-AC	159 000 678	Conductivity/Resistivity Controller, AC

## Accessories

Mfr. Part No	Code	Description
3-8050.395	159 000 186	NEMA 4X Rear Cover
3-9000.392	159 000 368	Liquid-tight Connector Kit for rear cover (includes 3 connectors)
3-8050.392	159 000 640	Model 200 Retrofit Adapter
3-5000.399	198 840 224	5x5 inch Adapter Plate for Signet retrofit
3-0000.596	159 000 641	Heavy Duty Wall Mount Bracket
3-5000.598	198 840 225	Surface Mount Bracket
3-8050.396	159 000 617	RC Filter Kit (for relay use)
3-2830	159 000 628	Conductivity Certification Tool
7300-7524	159 000 687	Power Supply, 7.5W 24 V
7300-1524	159 000 688	Power Supply, 15W 24 V
7300-3024	159 000 689	Power Supply, 30W 24 V
7300-5024	159 000 690	Power Supply, 50W 24 V
7300-1024	159 000 691	Power Supply, 100W 24 V

## Conductivity/Resistivity Electrodes

Mfr. Part No.	Code	Description
3-2819-1	198 844 010	Conductivity/Resistivity (CR) Cell, 0.01, SS
3-2820-1	198 844 000	Conductivity Cell, 0.1, SS
3-2821-1	198 844 001	Conductivity Cell, 1.0, SS
3-2822-1	198 844 002	Conductivity Cell, 10, SS
3-2823-1	198 844 003	Conductivity Cell, 20, SS
3-2819-S1	159 000 085	CR Sanitary, 0.01, SS, 1 to 1 1/2 in.
3-2819-S1C	159 000 087	CR Sanitary, 0.01, SS, 1 to 1 1/2 in., Certified
3-2819-S2	159 000 086	CR Sanitary, 0.01, SS, 2 in.
3-2819-S2C	159 000 088	CR Sanitary, 0.01, SS, 2 in., Certified
3-2819-T1	159 000 081	CR Sanitary, 0.01, Titanium, 1 to 1 1/2 in.
3-2819-T1C	159 000 083	CR Sanitary, 0.01, Titanium, 1 to 1 1/2 in., Certified
3-2819-T2	159 000 082	CR Sanitary, 0.01, Titanium, 2 in.
3-2819-T2C	159 000 084	CR Sanitary, 0.01, Titanium, 2 in., Certified
3-2820-S1	159 000 089	CR Sanitary, 0.1, SS, 1 to 1 1/2 in.
3-2820-S1C	159 000 091	CR Sanitary, 0.1, SS, 1 to 1 1/2 in., Certified
3-2820-S2	159 000 090	CR Sanitary, 0.1, SS, 2 in.
3-2820-S2C	159 000 092	CR Sanitary, 0.1, SS, 2 in., Certified
3-2820-T1	159 000 624	CR Sanitary, 0.1, Titanium, 1 to 1 1/2 in.
3-2820-T2	159 000 625	CR Sanitary, 0.1, Titanium, 2 in.
3-2821-S1	159 000 093	CR Sanitary, 1.0, SS, 1 to 1 1/2 in.
3-2821-S1C	159 000 095	CR Sanitary, 1.0, SS, 1 to 1 1/2 in., Certified
3-2821-S2	159 000 094	CR Sanitary, 1.0, SS, 2 in.
3-2821-S2C	159 000 096	CR Sanitary, 1.0, SS, 2 in., Certified
3-2821-T1	159 000 626	CR Sanitary, 1.0, Titanium, 1 to 1 1/2 in.
3-2821-T2	159 000 627	CR Sanitary, 1.0, Titanium, 2 in.
3-2839-1	159 000 921	Conductivity Cell, 0.01, 15 ft cable, NPT
3-2839-1D	159 000 923	Conductivity Cell, 0.01, 15 ft cable, ISO
3-2840-1	159 000 786	Conductivity Cell, 0.1, 15 ft cable, NPT
3-2840-1D	159 000 788	Conductivity Cell, 0.1, 15 ft cable, ISO
3-2841-1	159 000 790	Conductivity Cell, 1.0, 15 ft cable, NPT
3-2841-1D	159 000 792	Conductivity Cell, 1.0, 15 ft cable, ISO
3-2842-1	159 000 794	Conductivity Cell, 10.0, 15 ft cable, NPT
3-2842-1D	159 000796	Conductivity Cell, 10.0, 15 ft cable, ISO

NOTE: Alternate wetted materials and lengths are available through special order.  
Cable length extensions to 100 ft. (30 m) are available through special order.



Georg Fischer Signet LLC, 3401 Aerojet Avenue, El Monte, CA 91731-2882 U.S.A. • Tel. (626) 571-2770 • Fax (626) 573-2057  
For Worldwide Sales and Service, visit our website: [www.gfsignet.com](http://www.gfsignet.com) • Or call (in the U.S.): (800) 854-4090

