



3-2250.090

Rev. B 2/11

English

Safety Instructions

1. Prior to installation or removal:
 - Depressurize and vent system
 - Drain below sensor level
2. Confirm chemical compatibility before use.
3. Do not exceed maximum temperature/pressure specifications.
4. Wear safety goggles or faceshield during installation/service.
5. Do not alter product construction.
6. Dispose of properly; DO NOT INCINERATE!

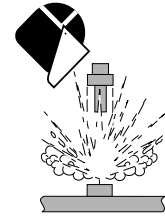
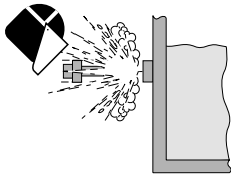

1. Description

The Signet 2250 Hydrostatic Level Sensor uses a gauge pressure sensor to calculate the level of fluid in a tank. Gauge pressure sensors measure the difference in pressure between the process on one side of a diaphragm and the atmospheric pressure on the opposite side of the diaphragm. A tiny capillary tube running from inside the sensor body and up the length of the cable provides the reference to atmospheric pressure.

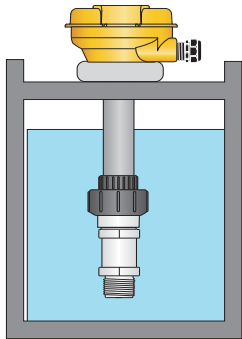

Hydrostatic level measurement can be a simple and practical solution to those applications where the fluid temperature is stable and constant.

IMPORTANT! This method of level measurement is not recommended if the fluid is subject to temperature variations or any other variable that causes the density of the fluid to change.

The 2250 Hydrostatic Level Sensor has excellent chemical compatibility. The wetted materials are PVDF, Ceramic and FPM.

Several different hardware mounting kits are available to accommodate every installation requirement.

2. Specifications

General

Compatibility: Signet 8250-2 and -3 Level Transmitters
Signet 8900 Multi-Parameter Controller

Wetted Material

- Sensor housing: PVDF
- Union nut/bushing: PVC-U
- Diaphragm: Ceramic
- Diaphragm seal: FPM (optional EPDM)

Cable type: 22 AWG, 3 conductor+capillary tube
Cable length: 10 m (32.8 ft) supplied
max. extension 120 m (400 ft)

Operating Temperature: 15 °C to 85 °C (5 °F to 185 °F)
Storage Temperature: -20 °C to 100 °C (-4 °F to 212 °F)
Operating Pressure: -XU: 0 to 0.7 bar (0 to 10 psig)
-XL: 0 to 3.4 bar (0 to 50 psig)

Electrical

- Digital (S³L) Output:
- Format: Serial ASCII, TTL level 9600 bps.
 - Accuracy: ±1% of full scale (±0.001 psi)
 - Power: 5 VDC nominal, 1.5 mA max. current (5 VDC min, 6.5 VDC max)
- Reverse polarity and short circuit protected

4 to 20 mA Output:

- Factory span:
 - -XU: 0 to 0.7 bar (0-10 psig) = 0-7 m (23 ft) of water
 - -XL: 0 to 3.4 bar (0-50 psig) = 0-34 m (115.5 ft) of water
- Accuracy: ±32 µA
- Resolution: <5 µA
- Response Time: <100 ms
- Loop Power Required: 12 to 24 VDC nominal, 22.1 mA max (10.8 VDC min. to 26.4 VDC max.)
- Max. Loop Impedance:
 - 100 Ω @ 12 V
 - 325 Ω @ 18 V
 - 600 Ω @ 24 V

Standards and Approvals:

- CE
- Manufactured under ISO 9001 for Quality and ISO 14001 for Environmental Management

Dimensions

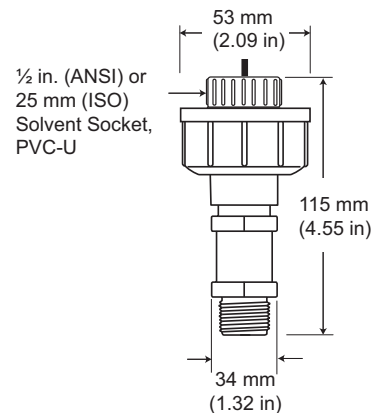

Installation

The 2250 can be assembled as a blind 4 to 20 mA signal connected by cable to a PLC, Chart recorder or other 4 to 20 mA device.
This type of installation requires no additional hardware.

The user must provide the 3/4 in. conduit to protect the cable from damage. The 2250 cable is not suitable for direct submersion.

Direct 4 to 20 mA output

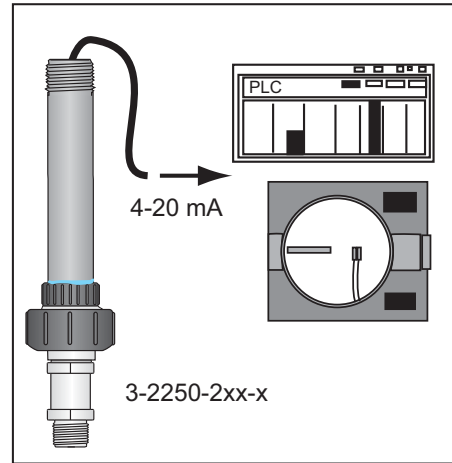

The 2250 can be assembled as a digital sensor connected directly to a Signet 8250 Level Transmitter or to a Signet 8900 Multi-Parameter Controller.

Direct Digital output

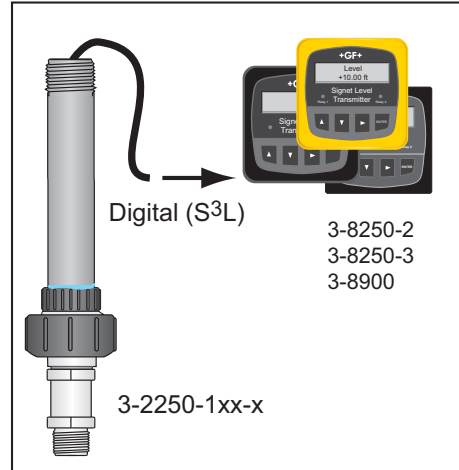

IMPORTANT!

A tiny capillary tube inside the sensor body is used to ensure that the back of the diaphragm remains at atmospheric pressure. If the capillary tube is blocked or damaged, the sensor cannot operate properly.

- If moisture is allowed to propagate down this tube to the rear of the diaphragm, the sensor may be damaged.
 - Do not allow the cable to be bent or compressed.
 - The ceramic diaphragm in the 2250 can be permanently damaged by over-pressure conditions or by mechanical contact.
- HANDLE THESE SENSORS WITH CARE.

2250 with 4 to 20 mA or Digital Output: Remote mounting

The 2250 can provide a digital (S³L) signal out to the 8250 Level Transmitter, to a PLC or to a chart recorder.

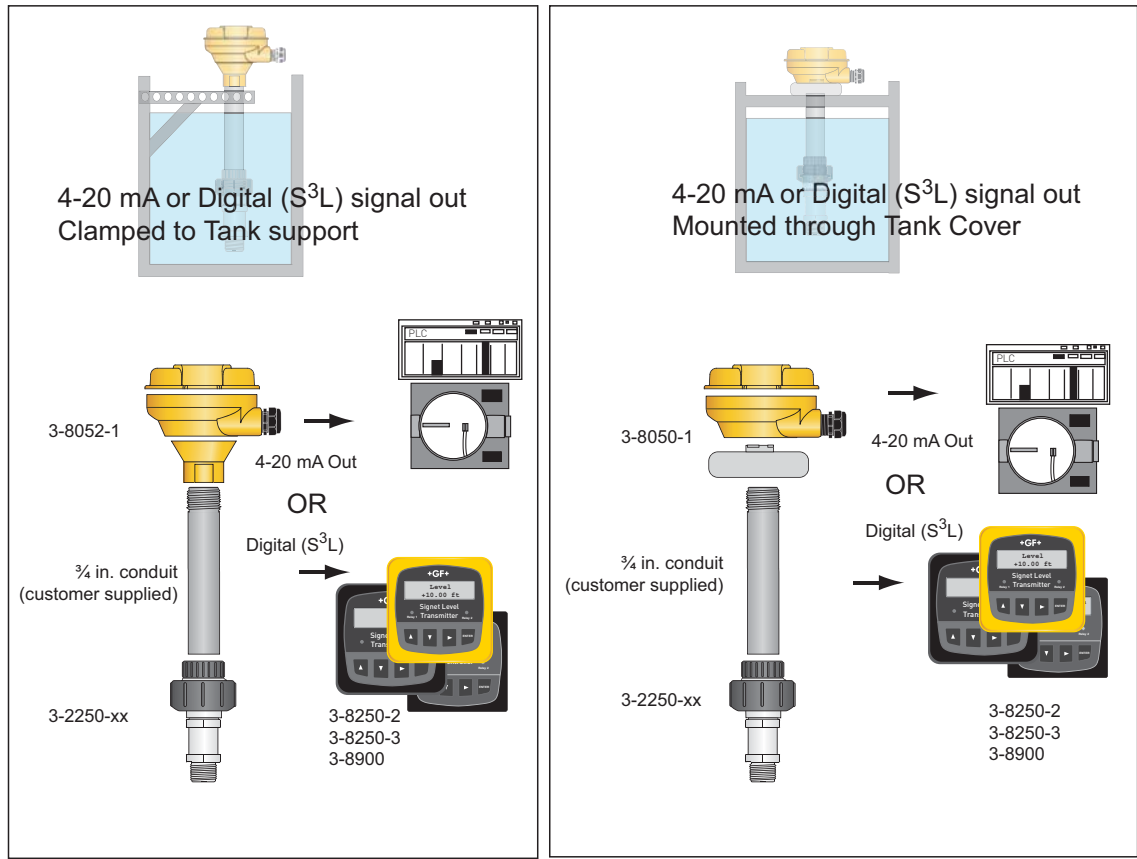

2250 with Digital Output: Integral mounting

The 2250 can be assembled as an integral system, with the 8250 Level Transmitter mounted directly atop the sensor.

This configuration provides a local display at the measurement site, plus the 4-20 mA and relay output features of the 8250 Transmitter.

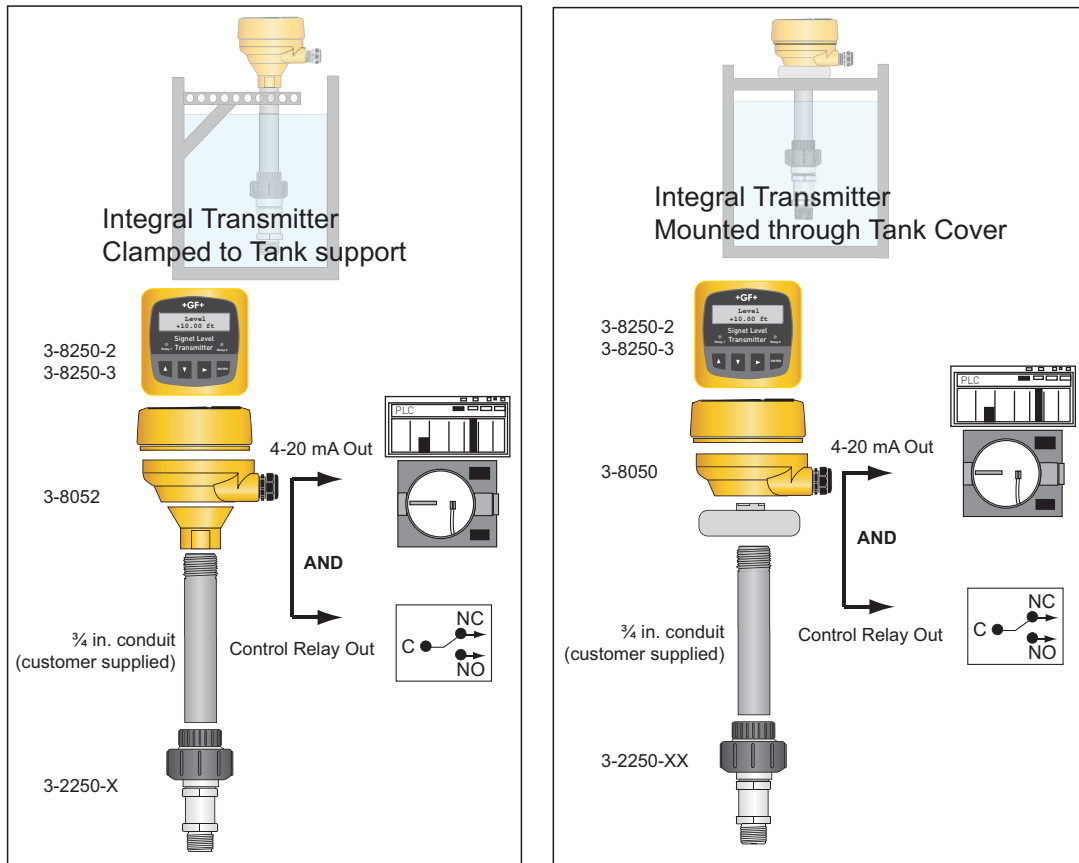

2250 Assembly Detail

1.

Glue the union bushing onto the conduit.

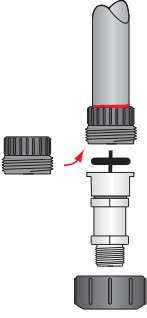

2.

Thread the sensor cable through the O-ring, Union and through the 3/4 in. conduit.



3.

Thread the Union nut onto the Union bushing.

CAUTION
Hand tighten the nut. Do not use tools.

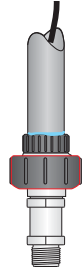

4.

Thread the 3/4 in. conduit adapter or the universal adapter onto the top of the conduit. Use a suitable thread sealant to provide a watertight connection.

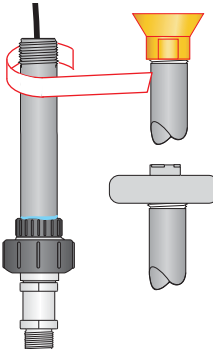

5.

Mount the conduit base onto the adapter and secure the assembly with the locking ring.



6A.

Remote system
Cut the cable to length and terminate the wires at the terminal block inside the conduit base.

CAUTION
The capillary tube that runs the length of the sensor cable must remain open to the atmosphere. Do not allow it to be crimped or blocked.

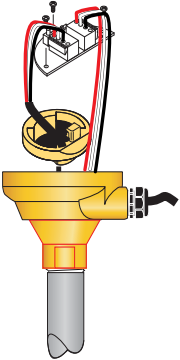
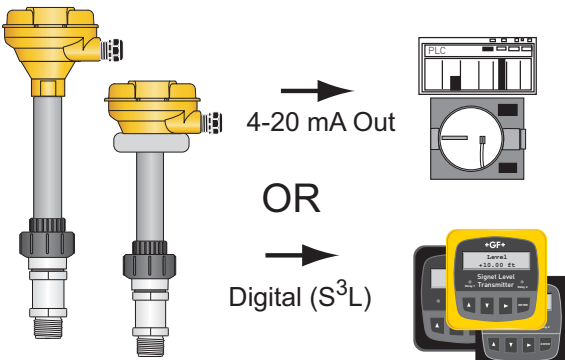
4-20 mA Out

OR

Digital (S³L)

6B.

Integral system
Cut the cable to length and terminate the wires at the terminal block of a field mount 8250 Transmitter.

CAUTION
The capillary tube that runs the length of the sensor cable must remain open to the atmosphere. Do not allow it to be crimped or blocked.

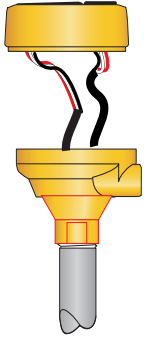
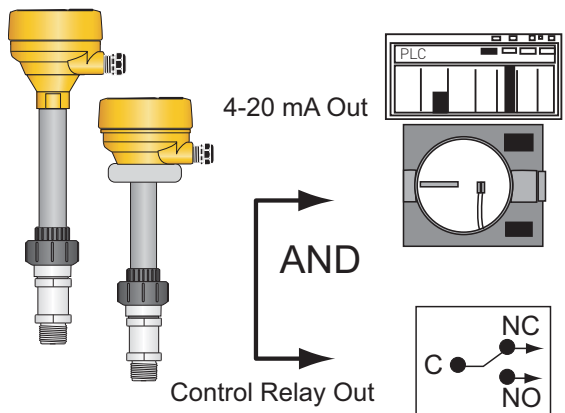
4-20 mA Out

AND

Control Relay Out

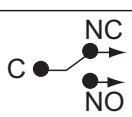

Digital (S³L) wiring

- The 2250 provides digital (S³L) output when powered with 5 VDC from the Transmitter or from the Multi-Parameter Controller.
- Connecting the SHIELD to a direct Earth ground may reduce electrical noise interference.
- The maximum digital (S³L) cable length is dependent upon the instrument to which the sensor is connected. Consult the instrument manual for details.

2250 to 8250-2 Level Transmitter

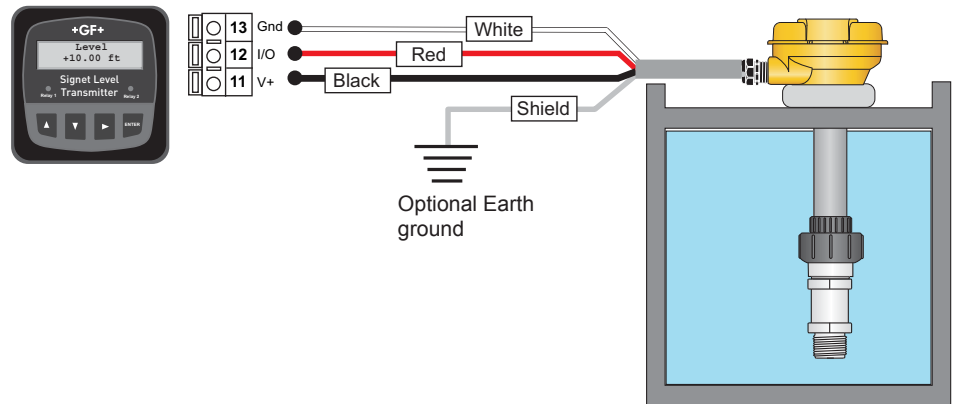

2250 to 8250-3 Level Transmitter

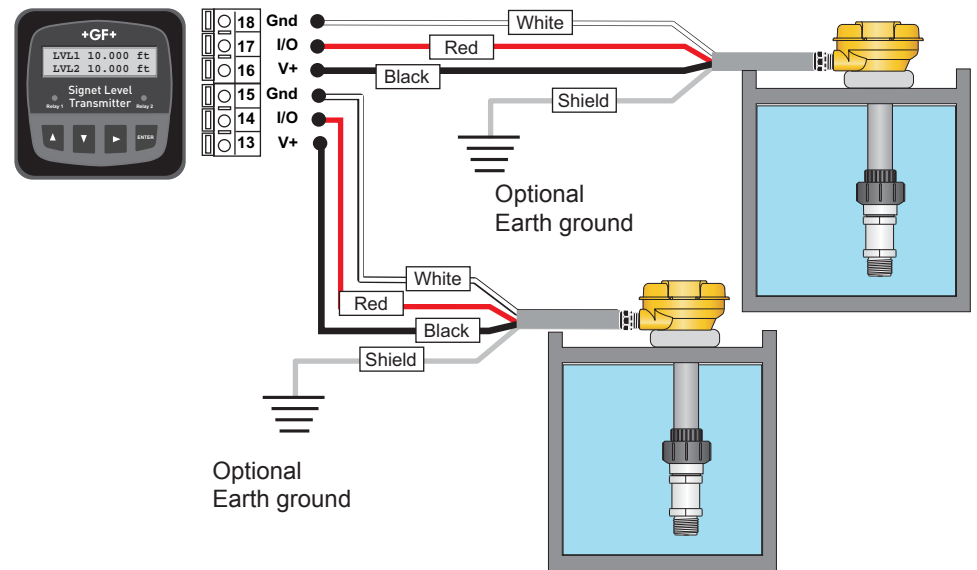

2250 to 8900 Multi-Parameter Controller

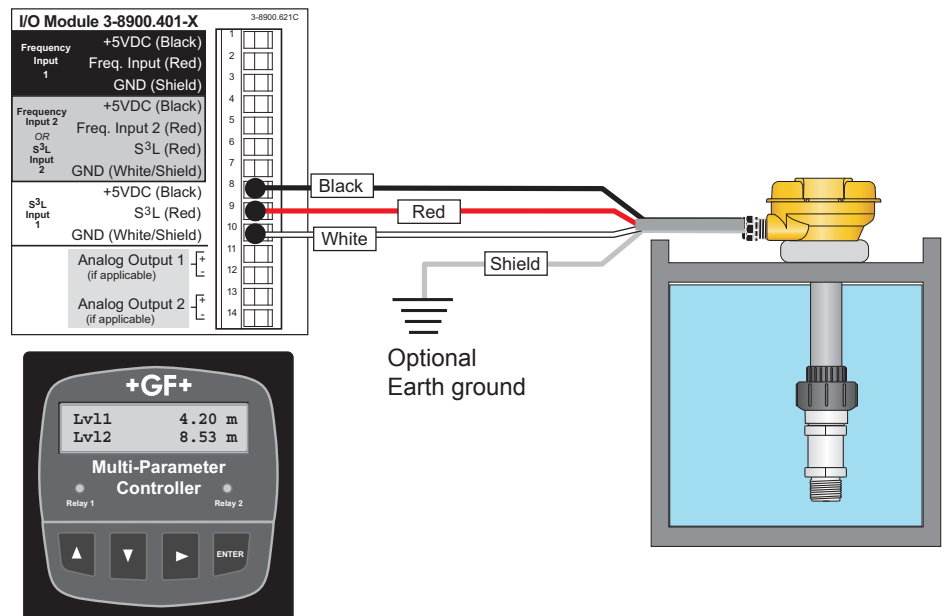

4 to 20 mA Loop Wiring

- The 2250-21x and 2250-22x models provide a 4 to 20 mA loop output when powered with 24 VDC.
- Connecting the SHIELD to a direct Earth ground may reduce electrical noise interference.

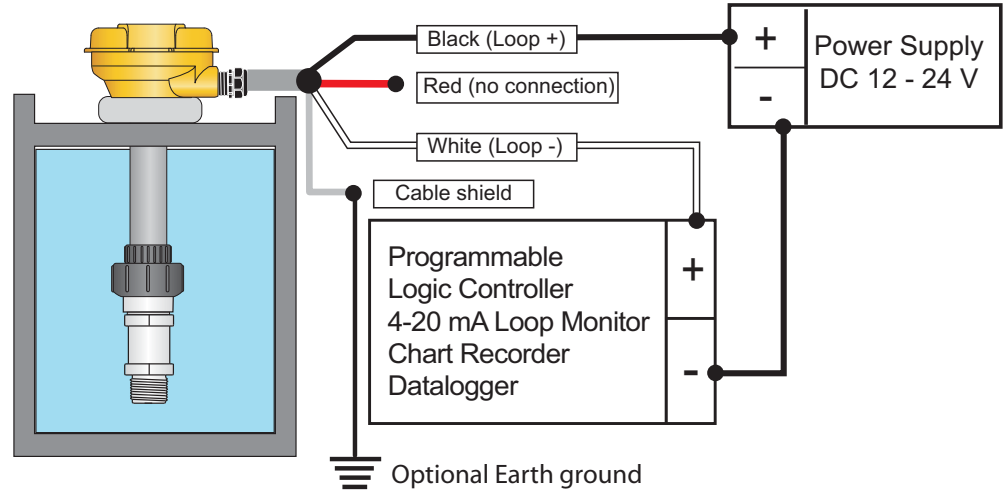

4 to 20 mA Span

- The 2250 is available in two factory-set span ranges:
 - Models numbers ending with "U" or "U-1" have a factory span of 0 to 10 psig.
 - Model numbers ending in "L" or "L-1" are spanned for 0 to 50 psig.
- The chart below lists the factory span of all available models.
- The level ranges in meters and feet are based on the mass of water.

Mfr. Part No.	Code	4-20 mA Span
3-2250-21U	159 001 248	4-20 mA = 0 to 0.7 bar (0-10 psig) 0 to 7 m (0 to 23.09 ft.)
3-2250-21L	159 001 247	4-20 mA = 0 to 3.4 bar (0-50 psig) 0 to 34 m (0 to 115.5 ft.)
3-2250-21U-1	159 001 482	4-20 mA = 0 to 0.7 bar (0-10 psig) 0 to 7 m (0 to 23.09 ft.)
3-2250-21L-1	159 001 483	4-20 mA = 0 to 3.4 bar (0-50 psig) 0 to 34 m (0 to 115.5 ft.)

Respanning the 4 to 20 mA output

- The 4 to 20 mA span can be set to accommodate any application within the operating range of the sensor.
- The respawning procedure requires that the sensor be subjected to the actual pressure that will represent 4 mA and 20 mA.
- The procedure illustrated here assumes that the application requires that the sensor output is 4 mA when the tank is empty and 20 mA when the tank is full. To reverse the range, reverse steps 3 and 5.

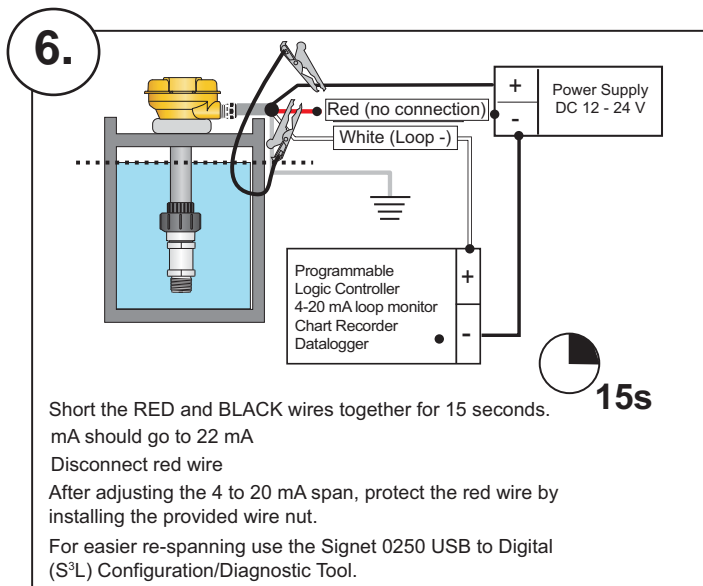
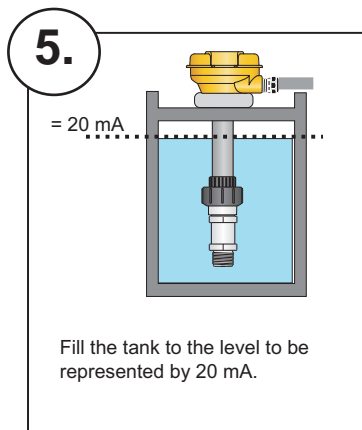
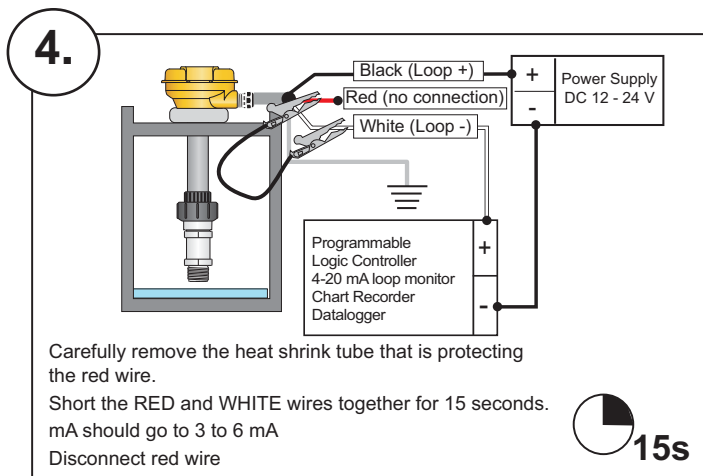
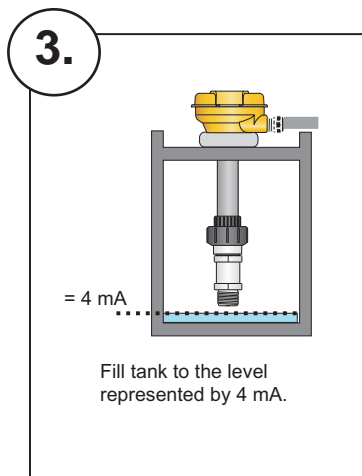
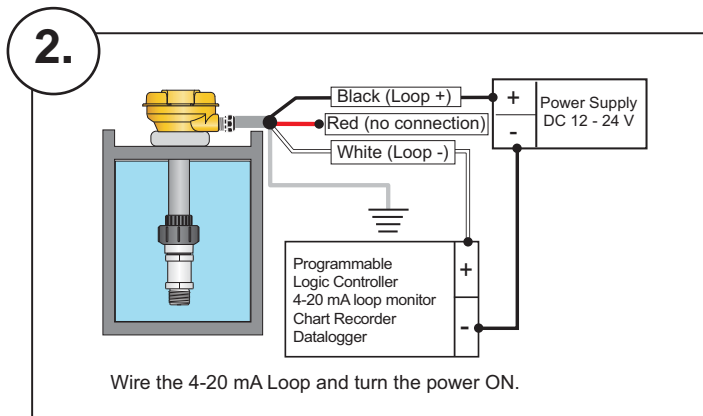
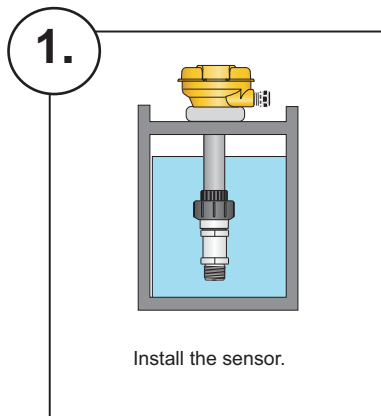

Ordering Information

Sensor Part Number	
3-2250	Hydrostatic Level Sensor
	Sensor Output
-1	Digital (S ³ L), 10 m (32.8 ft.)
-2	Current (4 to 20 mA), 10m (32.8 ft.)
	Threaded Connection
1	½ in. union connector
	Operating Pressure Range
U	0 - 0.7 bar (0-10 psi)
L	0 - 3.4 bar (0-50 psi)
	PVC-U Union Connection
-	¾ in. socket
-1	Metric pipe connector
3-2250	-1 1 U Example Part Number

Mfr. Part No.	Code	Mfr. Part No.	Code
3-2250-11U	159 001 242	3-2250-11U-1	159 001 478
3-2250-11L	159 001 241	3-2250-11L-1	159 001 479
3-2250-21U	159 001 248	3-2250-21U-1	159 001 482
3-2250-21L	159 001 247	3-2250-21L-1	159 001 483

Accessories and Replacement Parts

Mfr. Part No.	Code	Description
5523-0222	159 000 392	Sensor cable, (per ft.) Consult Factory for assistance
3-9000.392-1	159 000 839	Liquid tight connector kit, NPT (1 pc.)
3-9000.392-2	159 000 841	Liquid tight connector kit, PG 13.5 (1 pc.)
3-8050	159 000 184	Universal mount kit
3-8052	159 000 188	¾ in. Integral mount kit
3-8050-1	159 000 753	Universal Mount w/Junction terminals
3-8052-1	159 000 755	¾ in. Integral mount w/Junction terminals
3-0250	159 001 538	USB to digital (S ³ L) configuration/diagnostic tool



Georg Fischer Signet LLC, 3401 Aerojet Avenue, El Monte, CA 91731-2882 U.S.A. • Tel. (626) 571-2770 • Fax (626) 573-2057
 For Worldwide Sales and Service, visit our website: www.gfsignet.com • Or call (in the U.S.): (800) 854-4090
 For the most up-to-date information, please refer to our website at www.gfsignet.com